

THE SMITH	
STANDARD FEATURES	
TOTAL LIVING AREA	2024 SQ. FT.
GARAGE / STORAGE	958 SQ. FT.
COVERED PORCH	208 SQ. FT.
COVERED DECK	360 SQ. FT.
OPTIONAL FEATURES	
OPT FINISHED BASEMENT	1391 SQ. FT.
OPT BAY WINDOW	N/A
TOLTAL UNDER ROOF	3636 SQ. FT.
OUTSIDE DIMENSIONS	
OVERALL WIDTH	69'-4"
OVERALL DEPTH	68'-4"

TABLE OF CONTENTS	
PAGE NO.	TITLE
1	COVER PAGE
2	FLOOR PLAN
3	FOUNDATION PLAN
4	FRONT & RIGHT SIDE ELEVATIONS
5	REAR & LEFT SIDE ELEVATIONS
6	ROOF PLAN
7	CROSS SECTION
8	WALL SECTIONS
9	FOUNDATION WALL DETAILS
10	GENERAL NOTES
D-1	BASEMENT EGRESS
S-1	LOWER LEVEL WALL BRACING
S-2	PORTAL FRAMING DETAIL

CODE COMPLIANCE	
INTERNATIONAL RESIDENTIAL CODE 2012	
VIRGINIA USBC 2012 EDITION	



FRONT ELEVATION

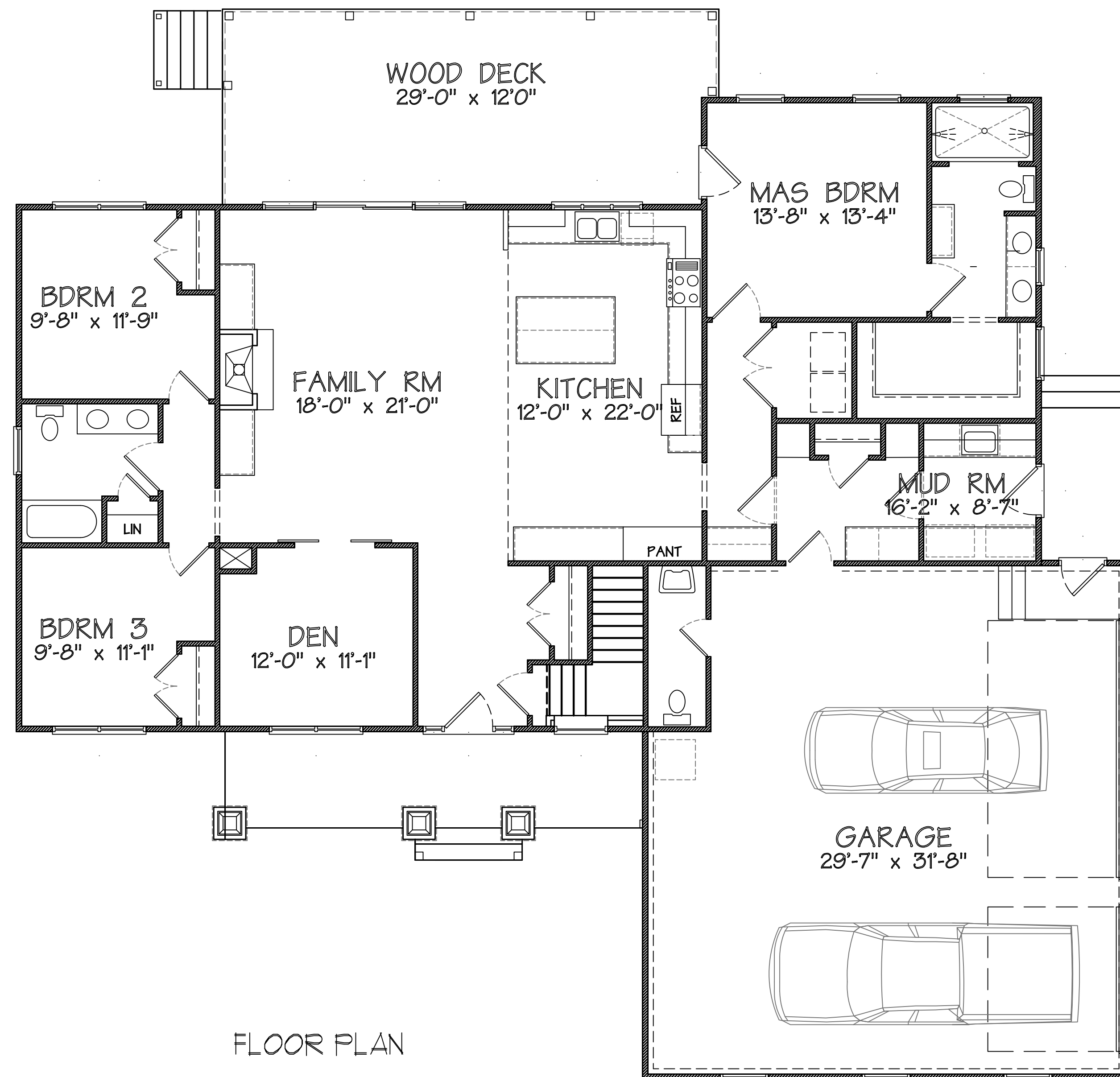

FLOOR PLAN

THE SMITH RESIDENCE

ELEVATION "A"

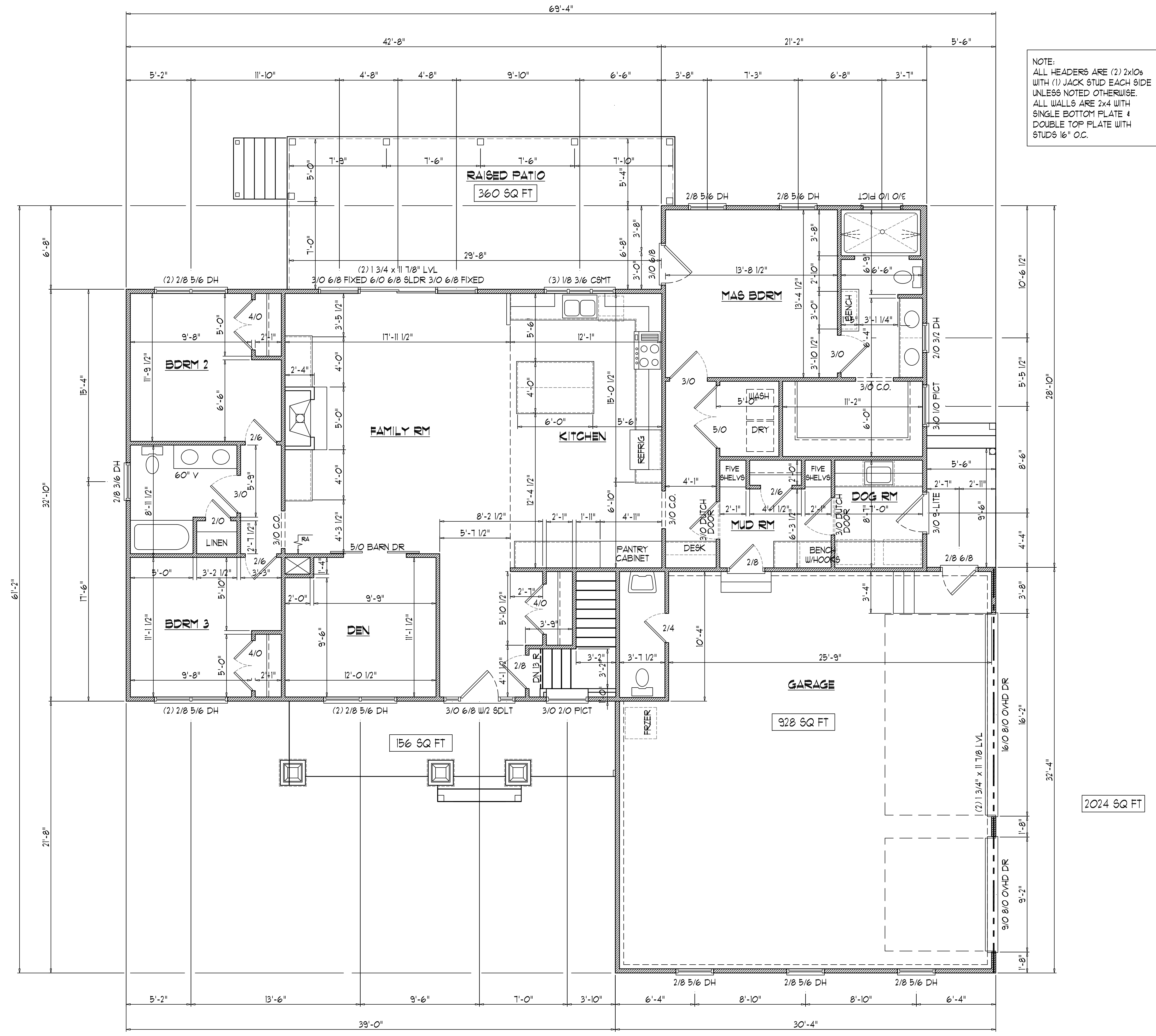

FLOOR PLAN

MIKE CALVIN - PLANSHOP LLC
 11505 ROSLYN ROAD
 FREDERICKSBURG, VA 22401
 PHONE: (540) 786-4221 FAX: (540) 785-1113

FILE: SMITH6.DWG
 DATE: 03/22/18
 SCALE: 1/4" INCH = 12" INCH
 PAGE: 2 OF 10

THE SMITH RESIDENCE
 FLOOR PLAN

PLANSHOP.BIZ
 HOMES DESIGNED FOR OPTIMUM VALUE

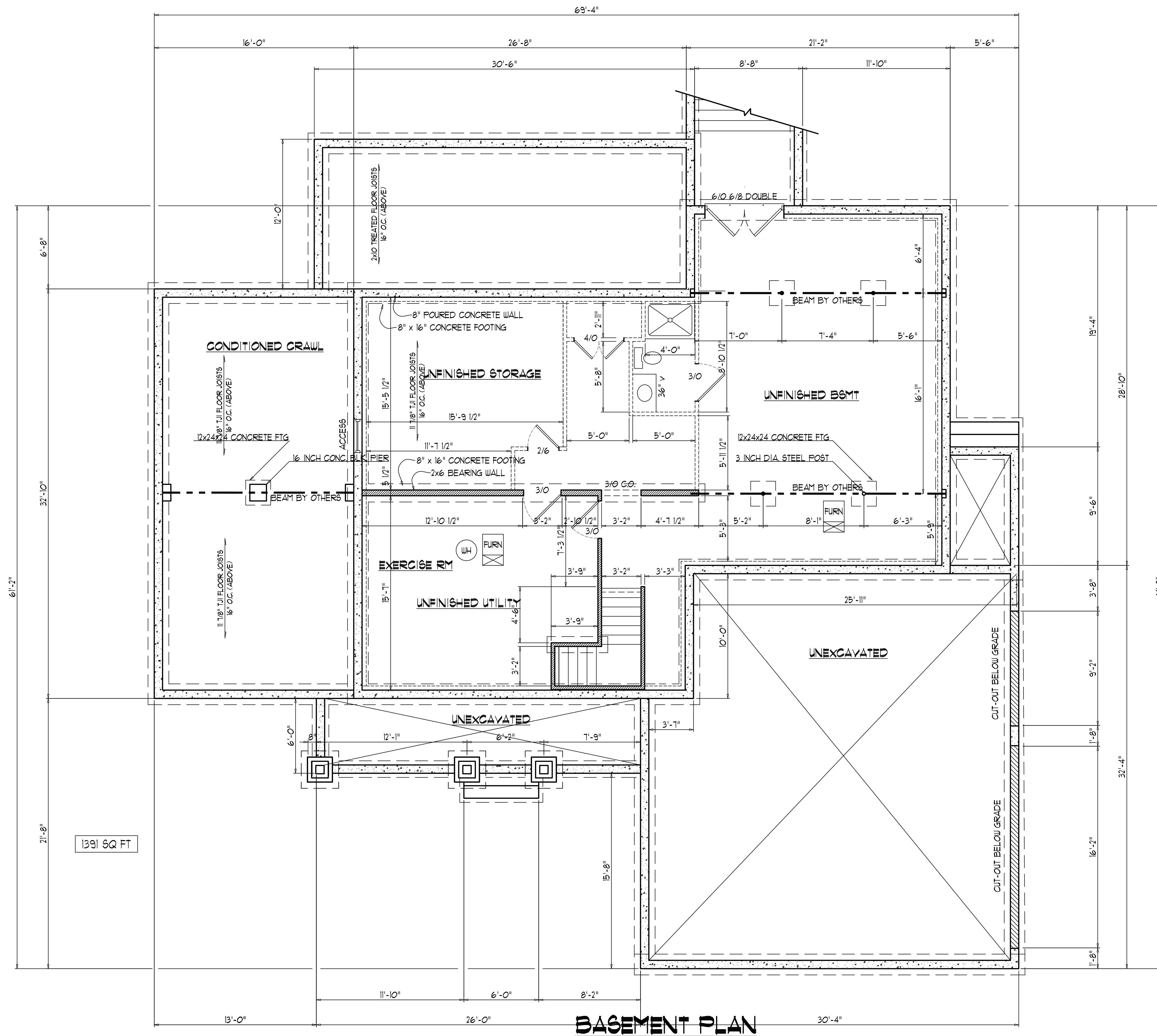

BASEMENT PLAN

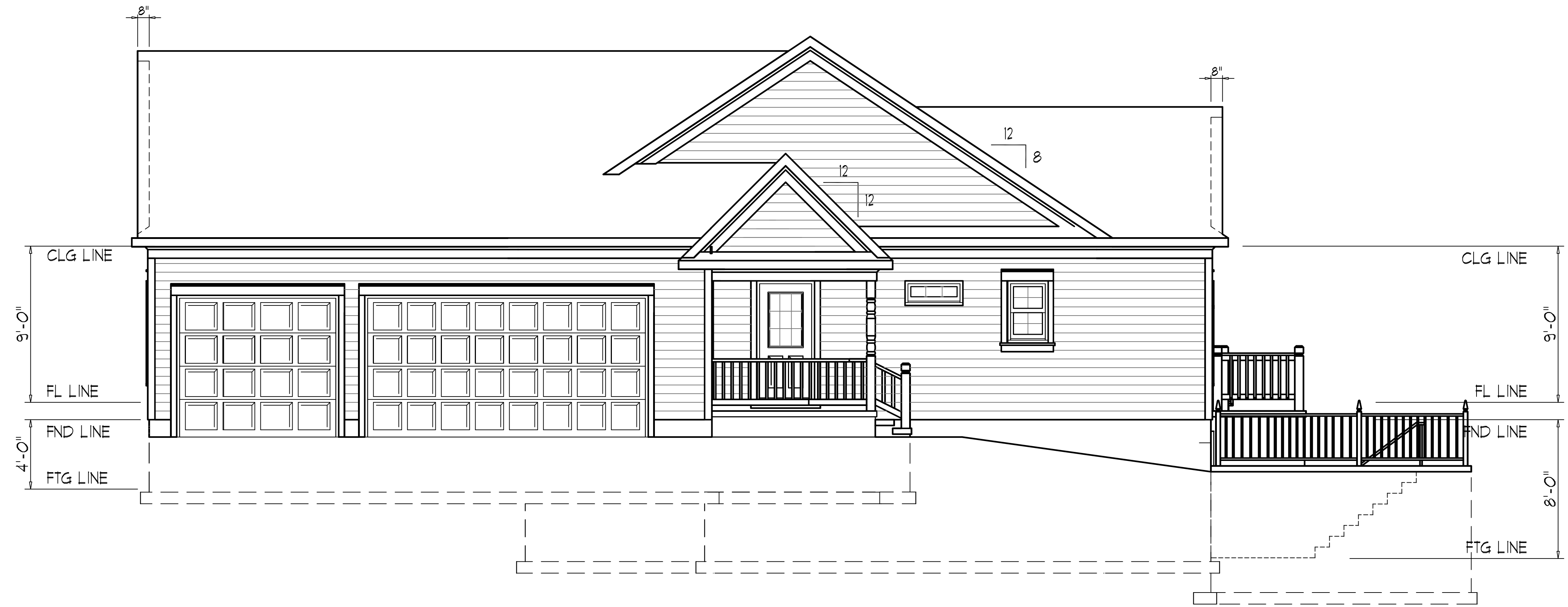

RIGHT SIDE ELEVATION

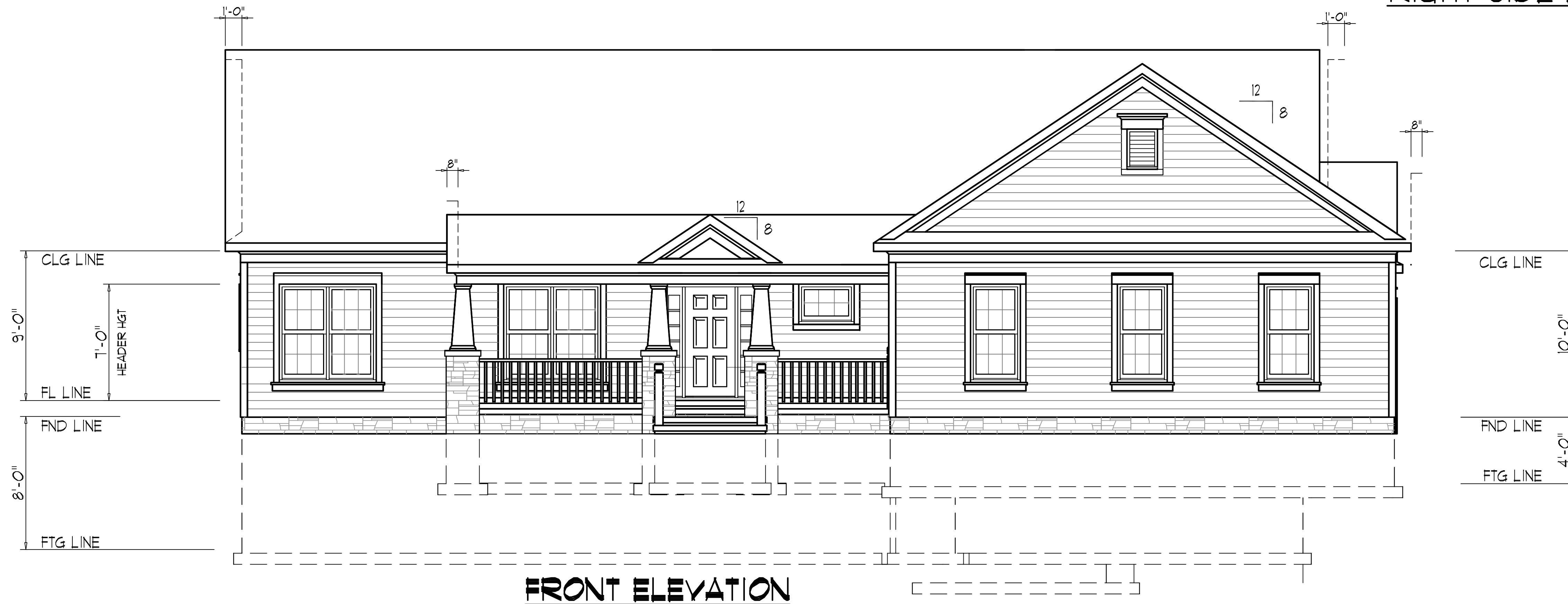

FRONT ELEVATION

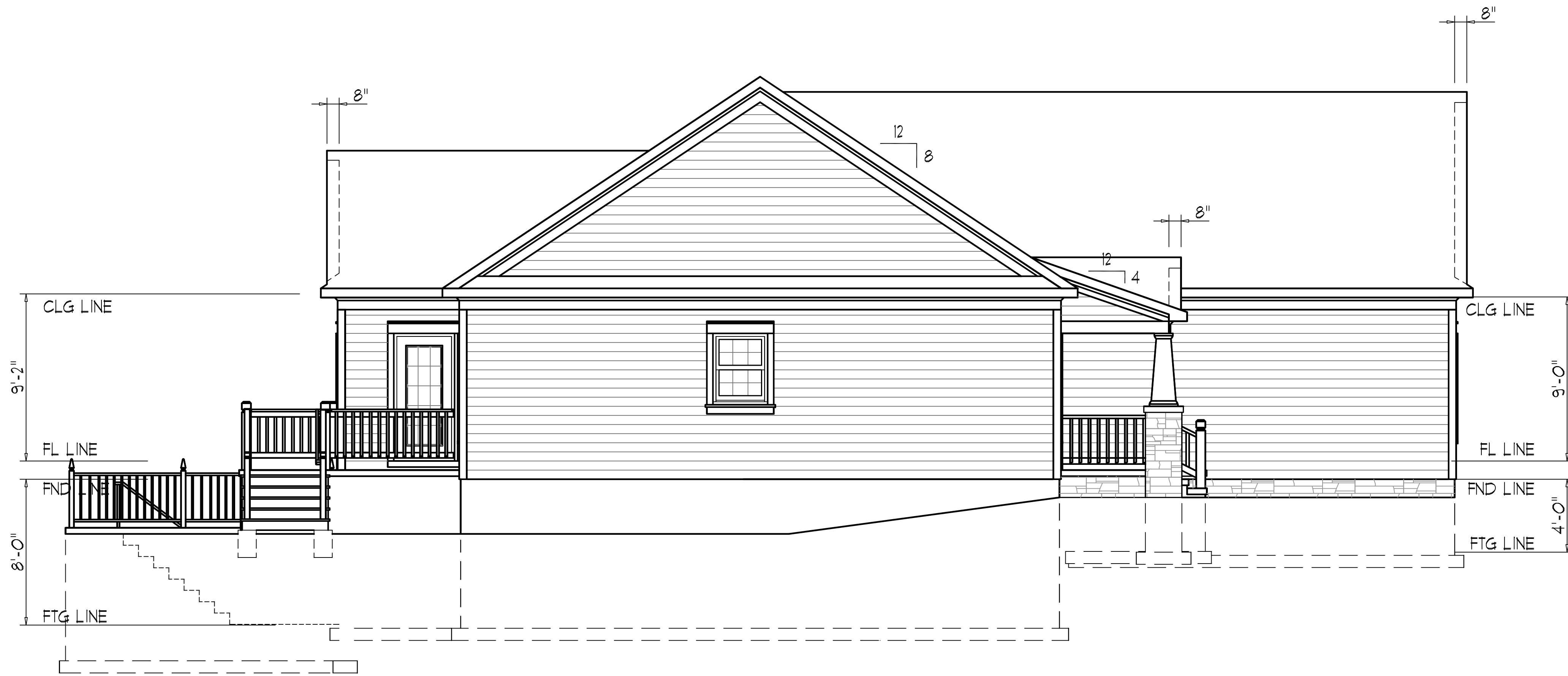

LEFT SIDE ELEVATION



REAR ELEVATION

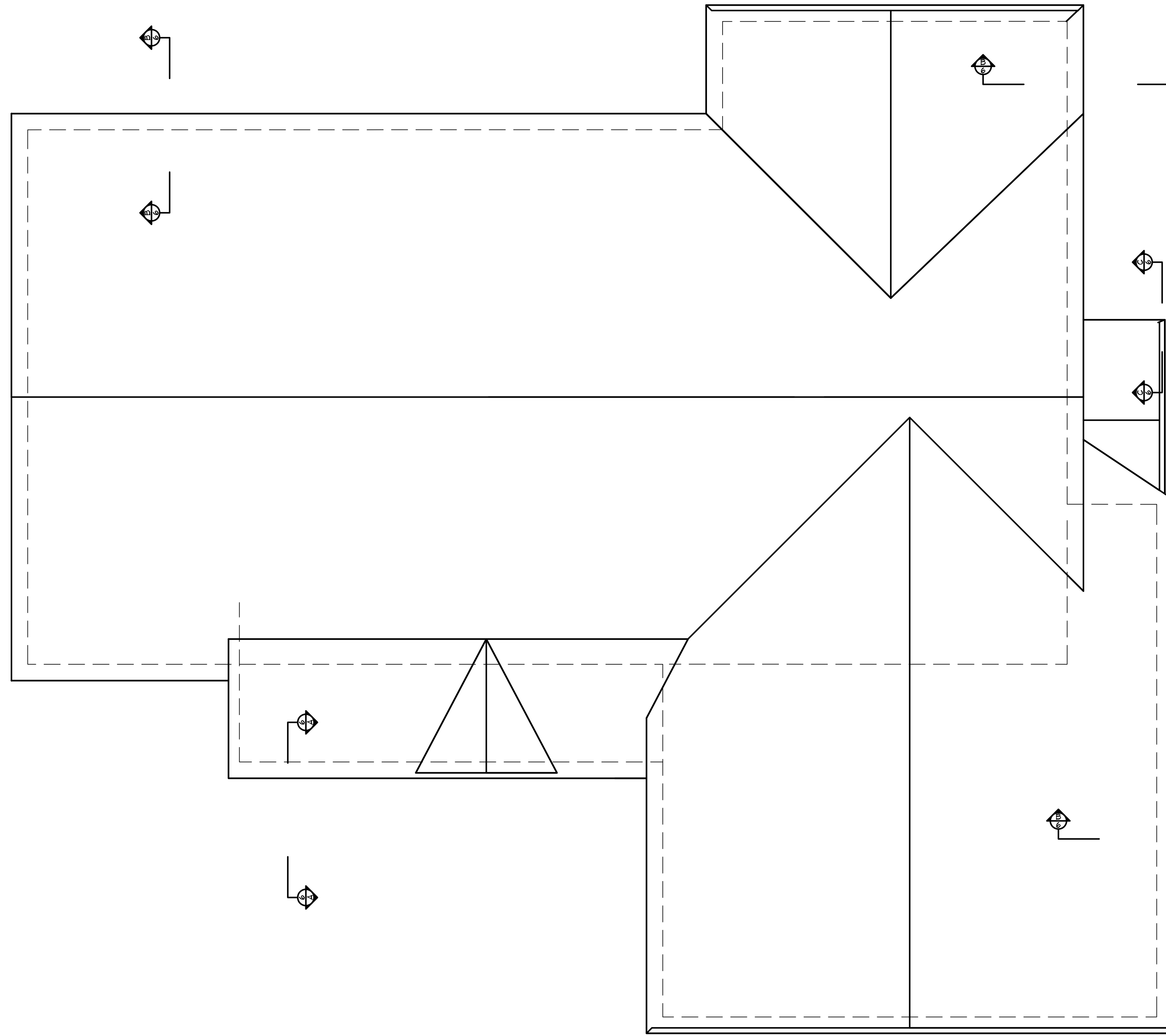

ROOF PLAN

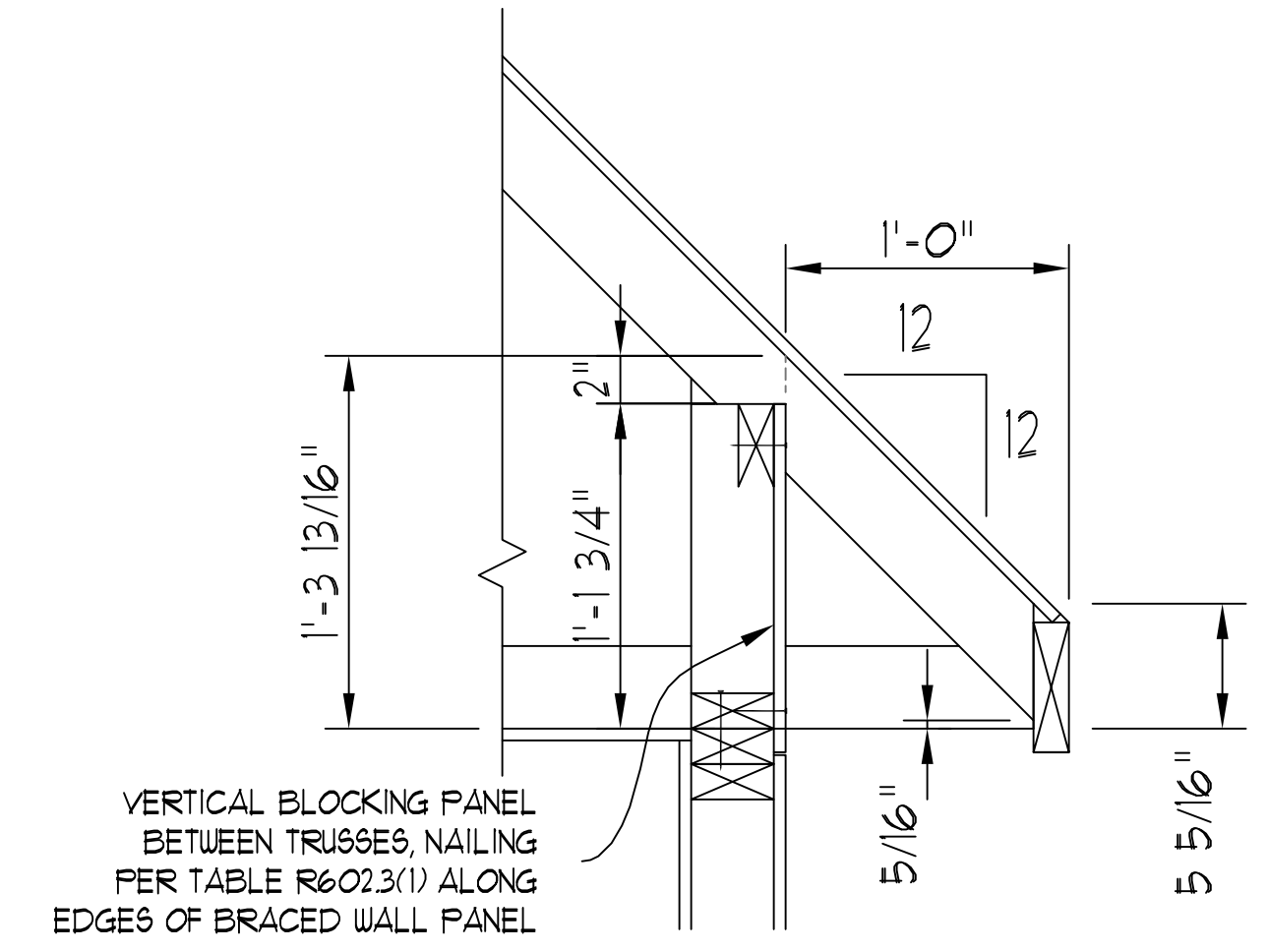

SECTION "C-6"
SCALE - 3/4" = 12"

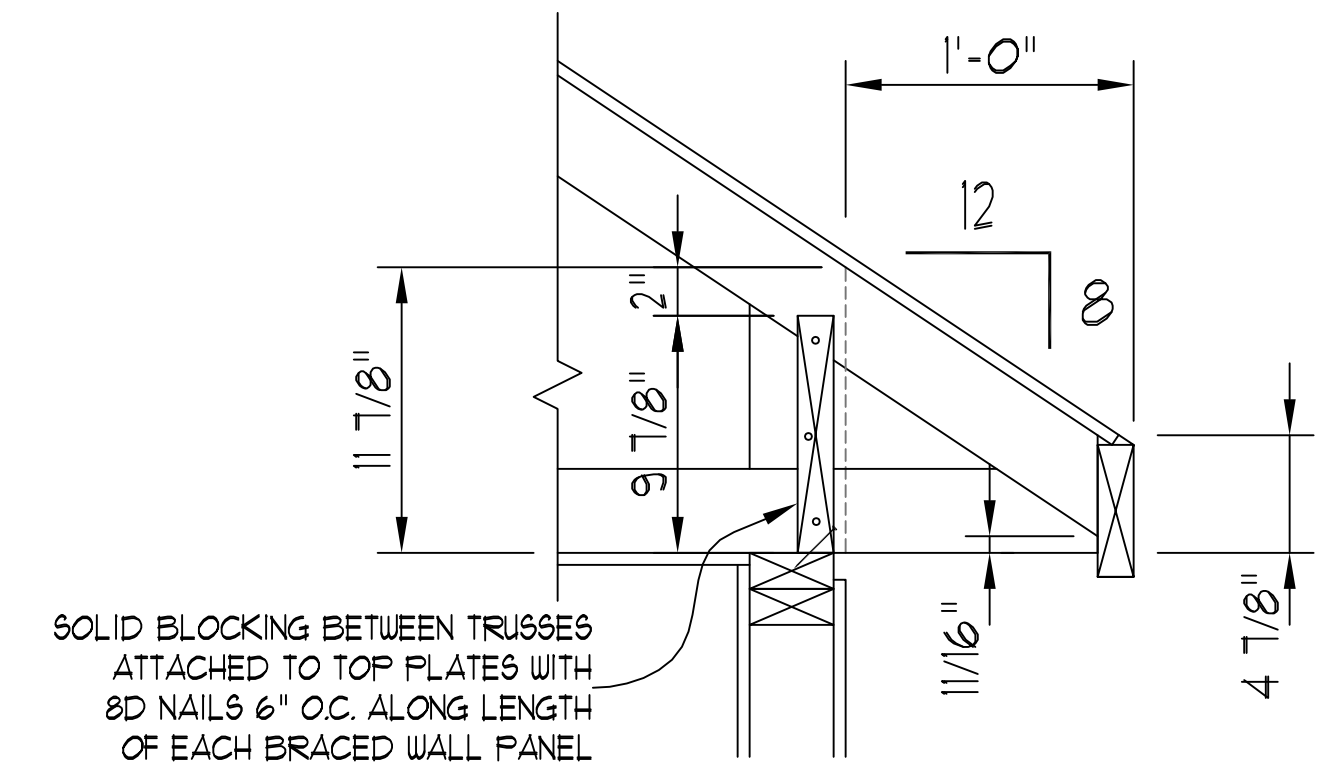

SECTION "B-6"
SCALE - 3/4" = 12"

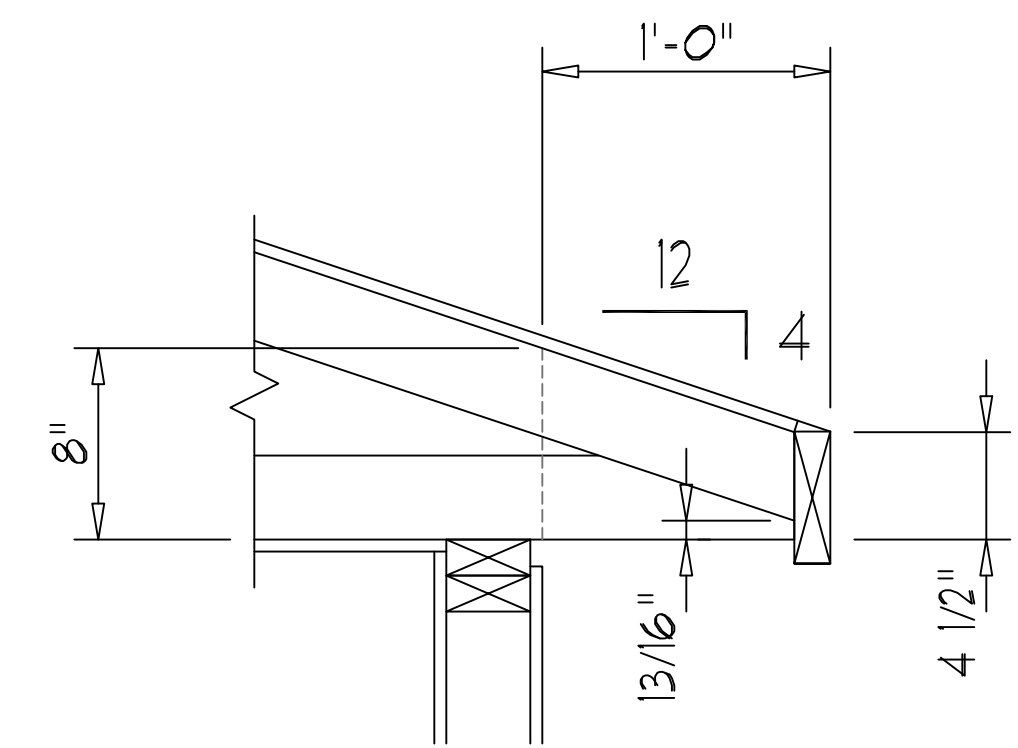

SECTION "A-6"
SCALE - 3/4" = 12"

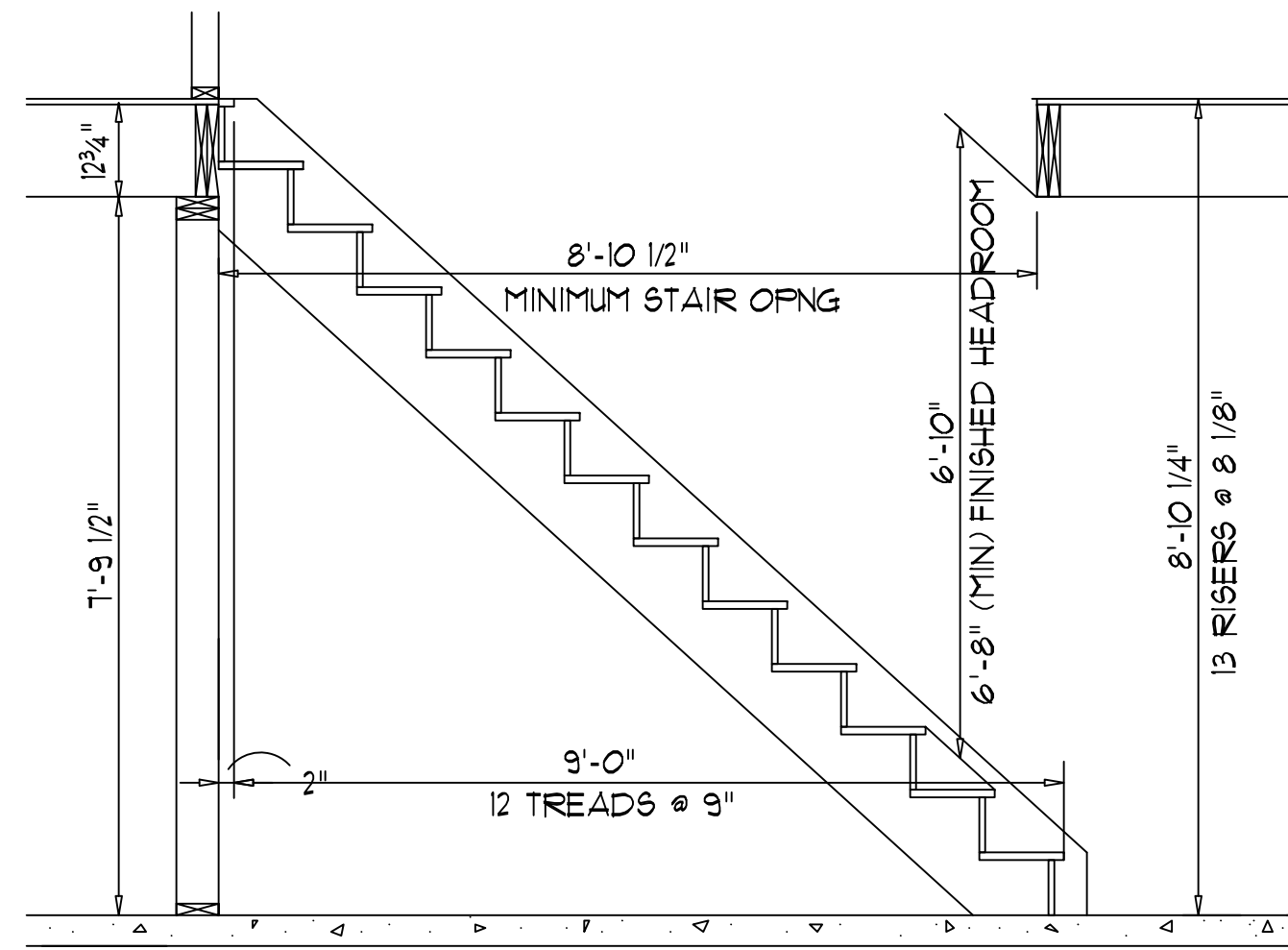

STAIR SECTION

SCALE: 1/2" = 12"

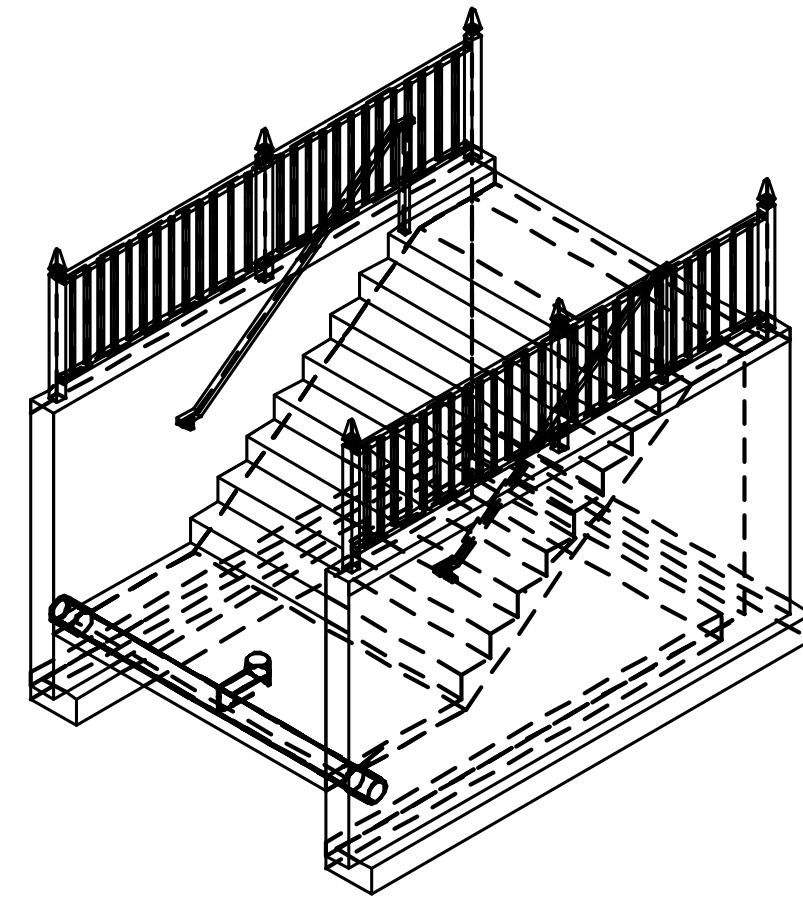

ISOMETRIC VIEW

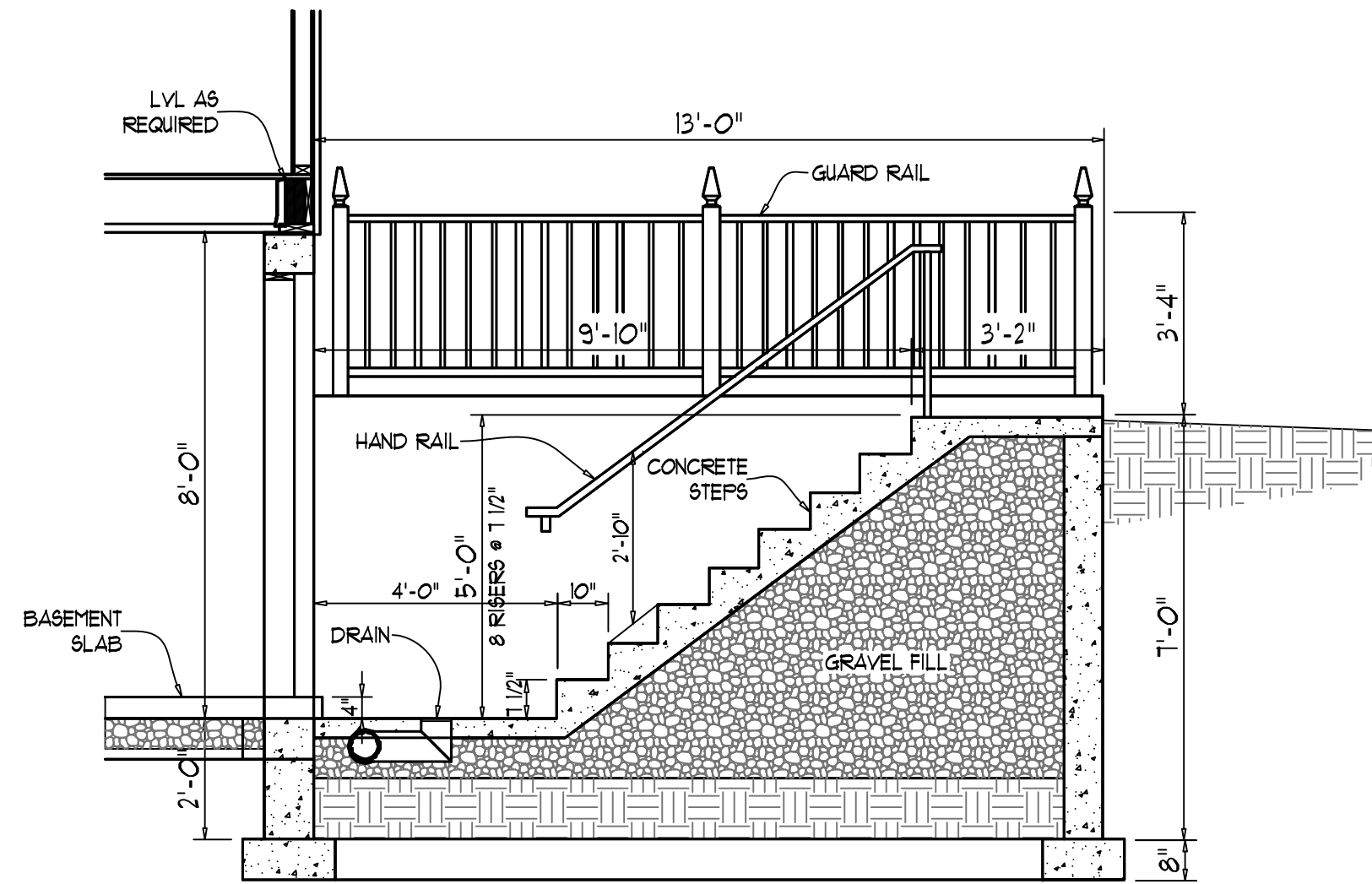

CROSS SECTION

SCALE: 3/8" = 12"

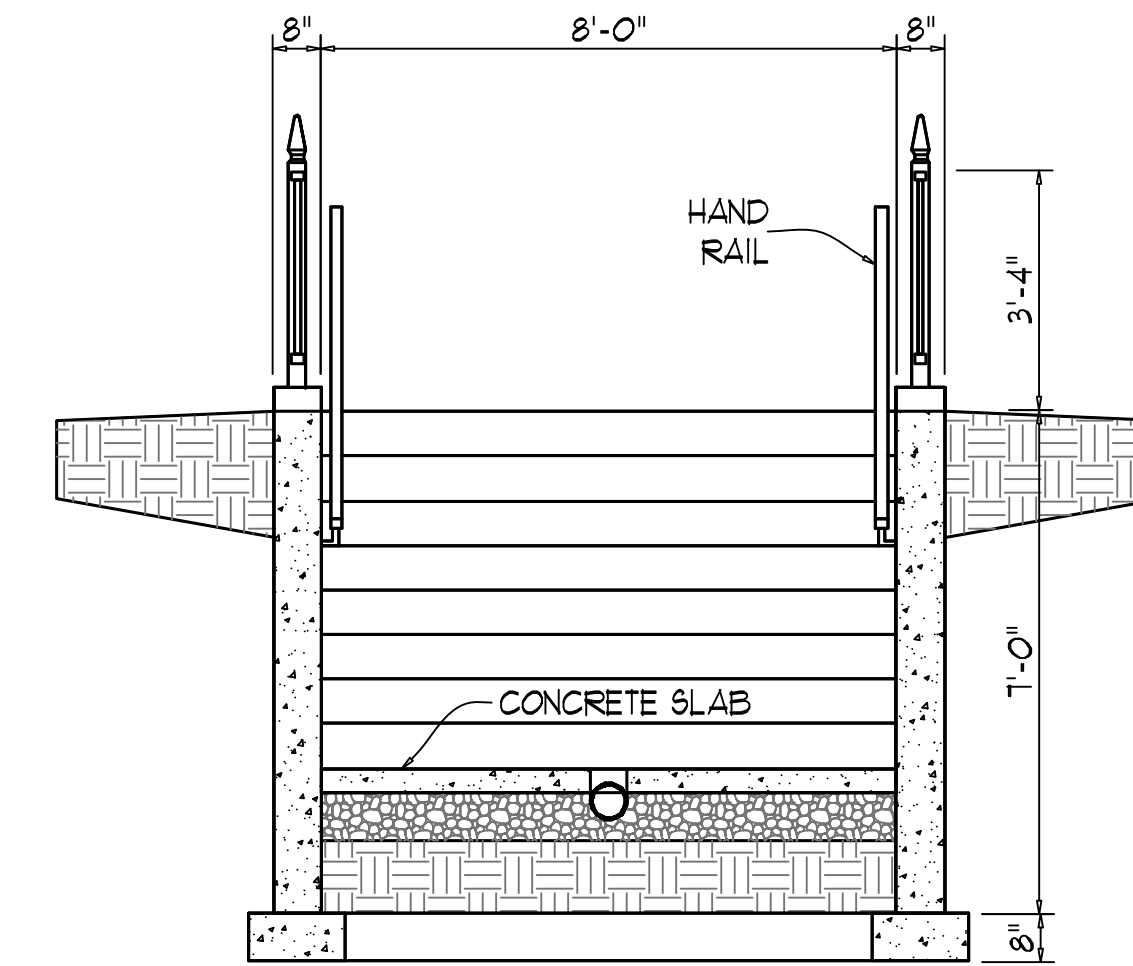

FRONT VIEW

SCALE: 3/8" = 12"

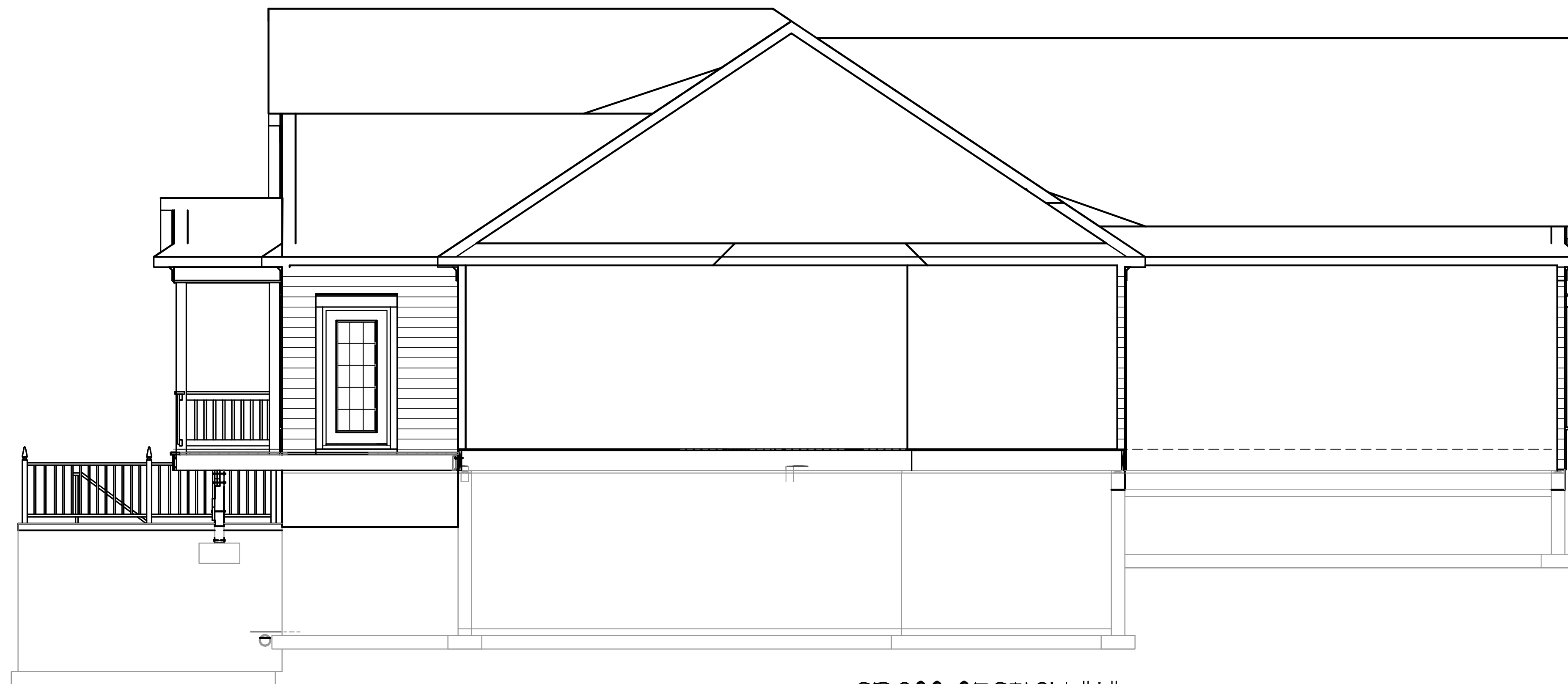

CROSS SECTION "A"

SCALE: 1/4" = 12"

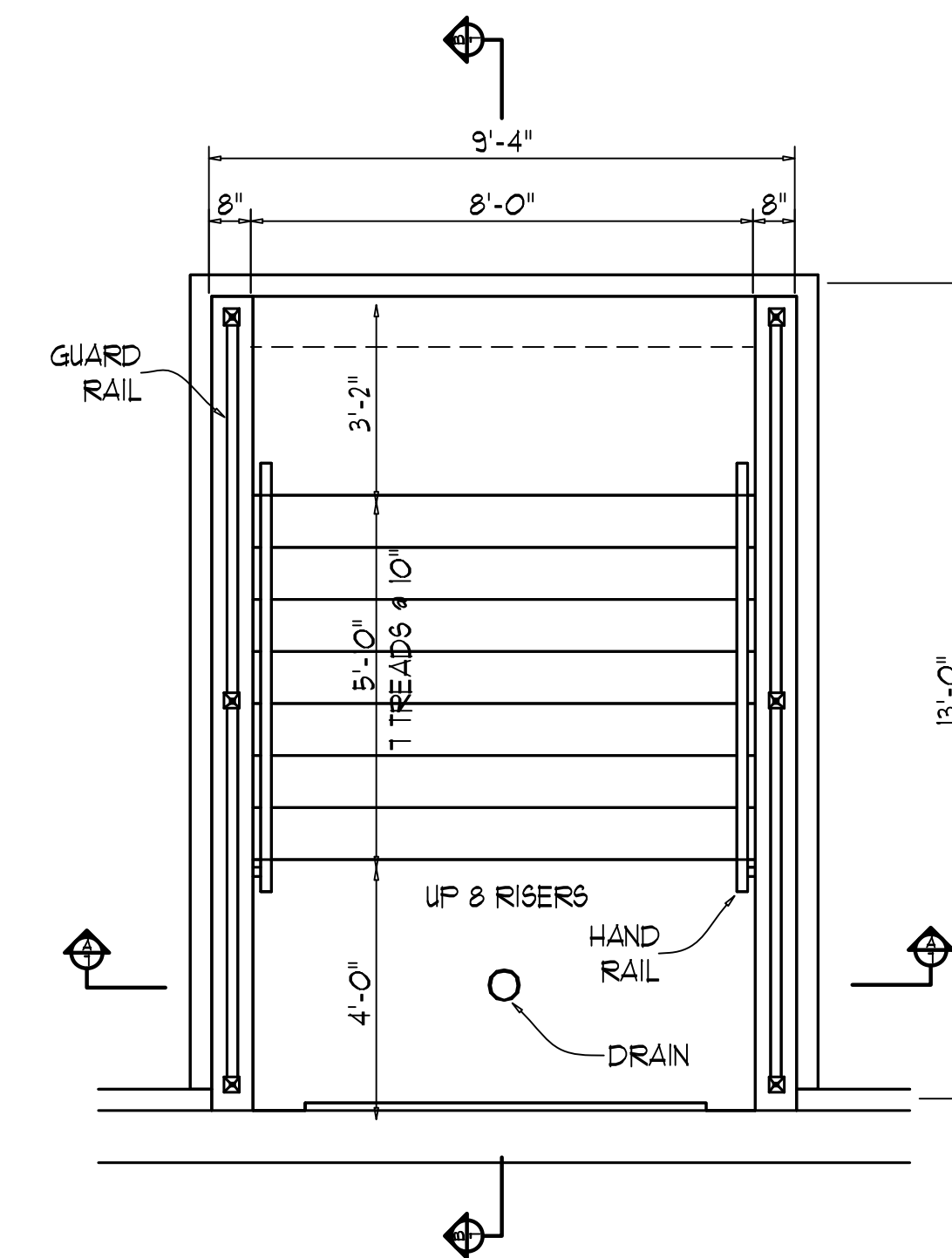

PLAN VIEW

SCALE: 3/8" = 12"

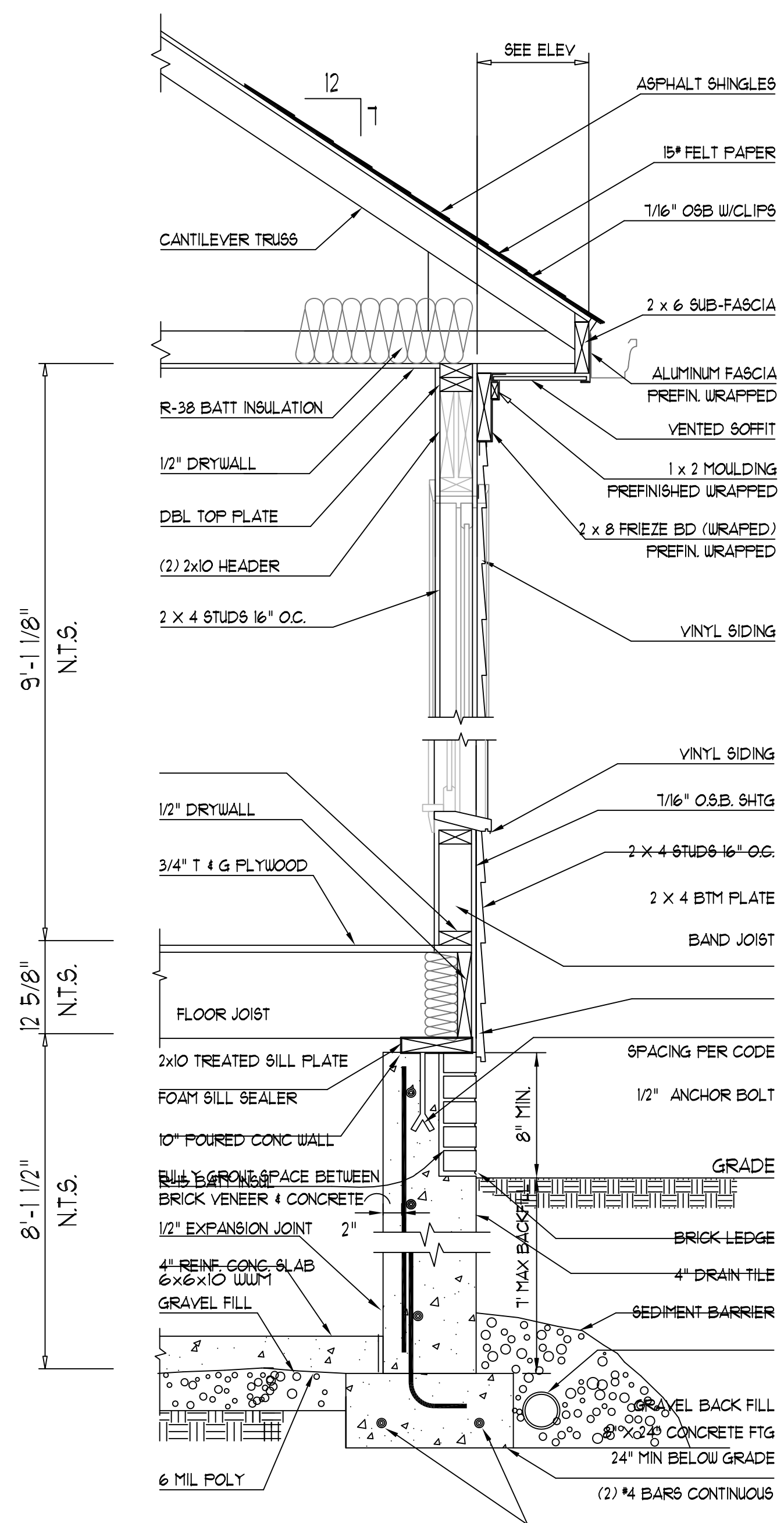

A-8 TYPICAL 1-STORY SECTION

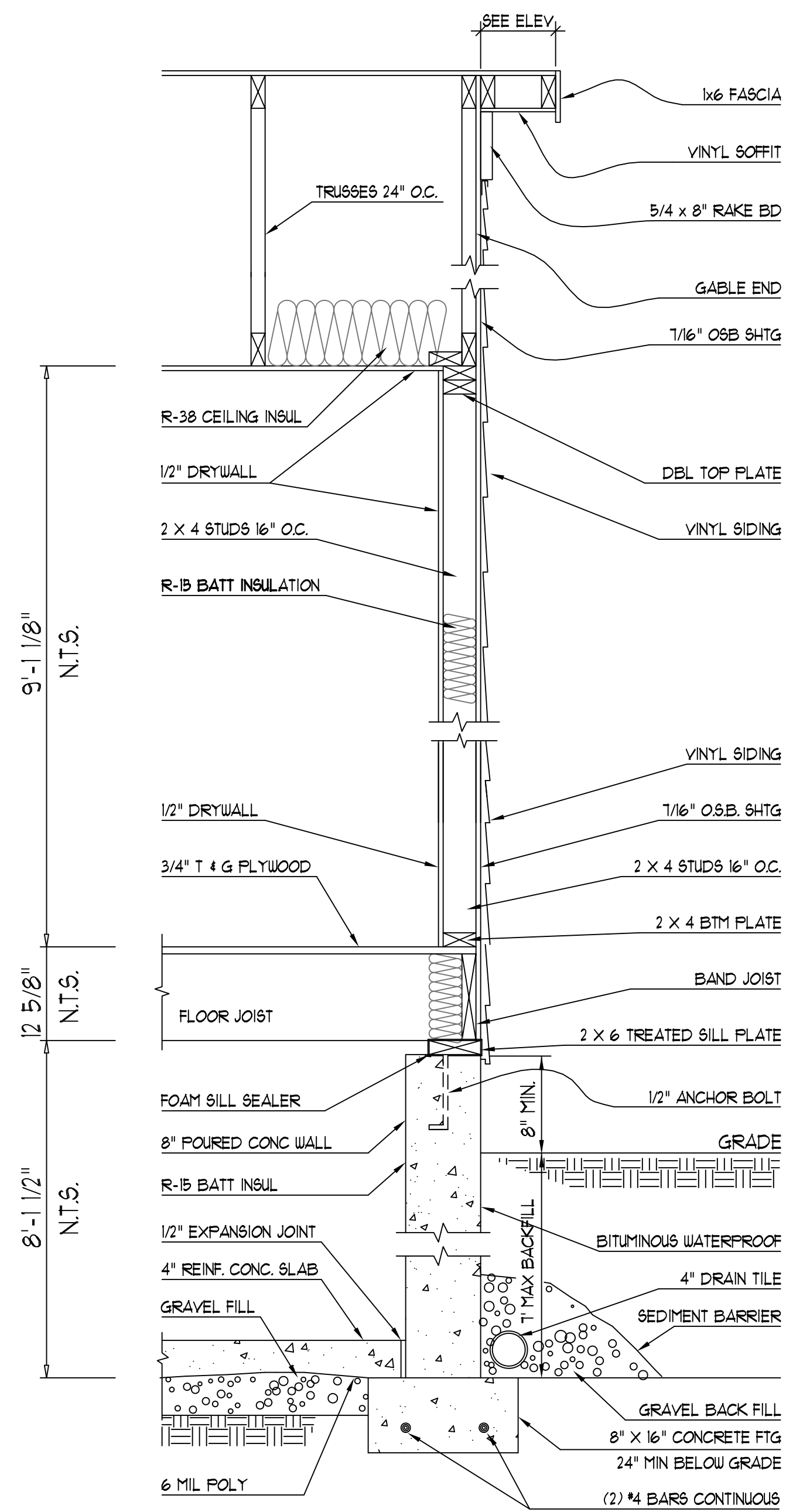

B-8 TYPICAL 1-STORY GABLE

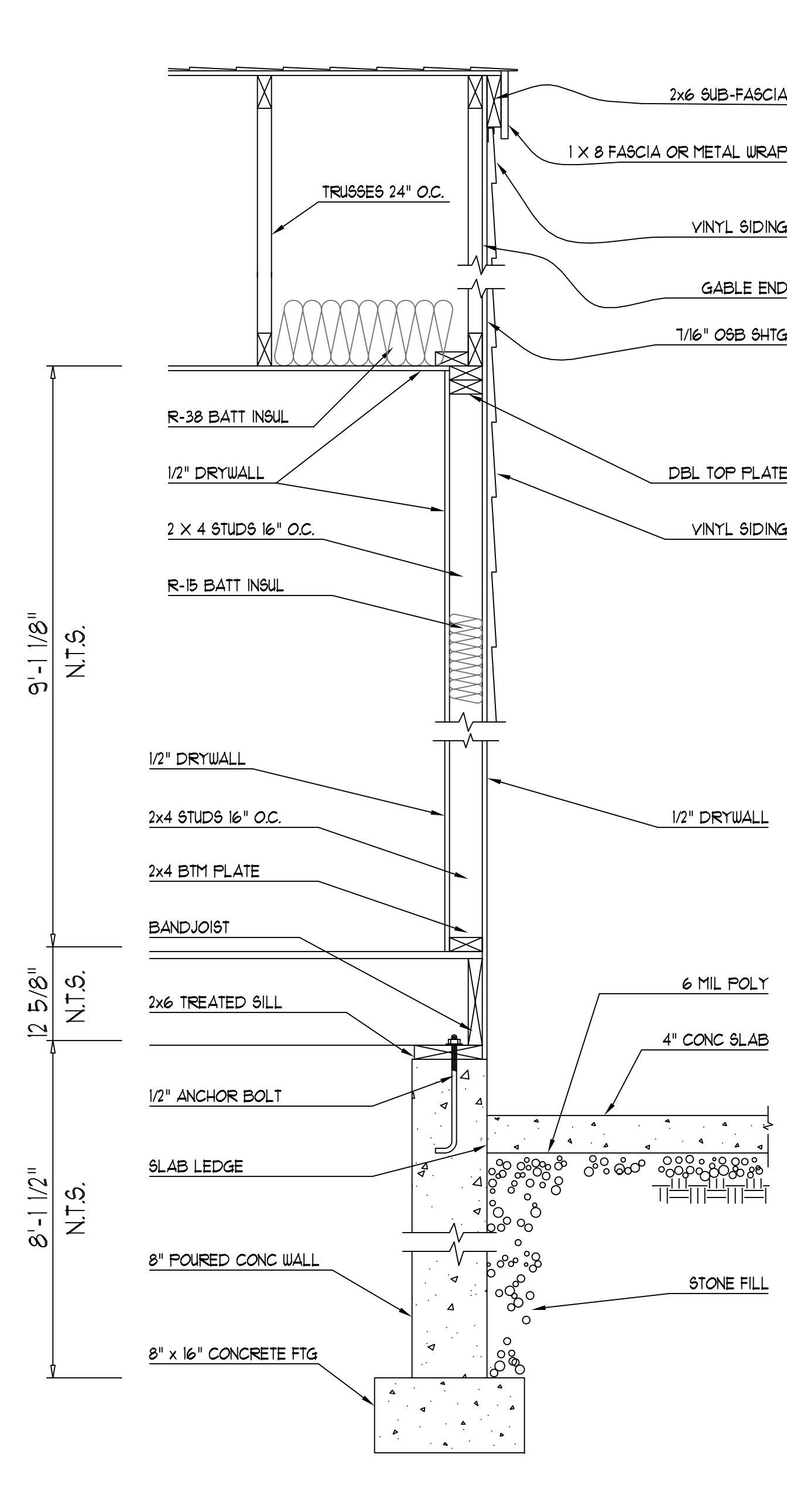

C-8 COMMON GARAGE WALL

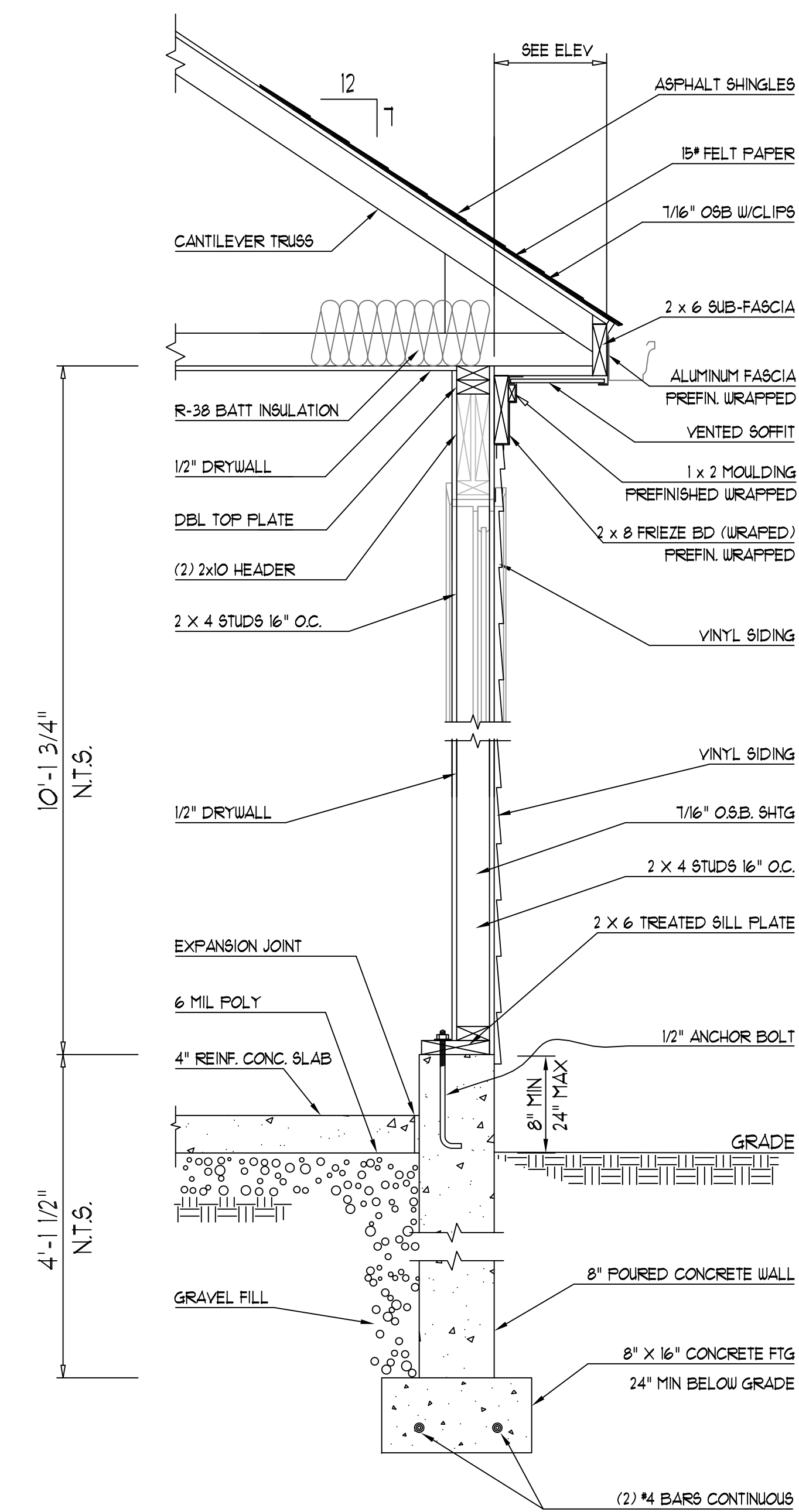

D-10 TYPICAL GARAGE WALL SECTION

VERTICAL REBAR SPACING

1 FT. TO 1.5 FT. FILL - #4 BARS @ 12" O.C.
 6 FT. TO 1 FT. FILL - #4 BARS @ 18" O.C.
 5 FT. TO 6 FT. FILL - #4 BARS @ 24" O.C.
 LESS THAN 5 FT. - NO VERTICAL BARS REQUIRED
 BALANCED FILL - NO VERTICAL REBAR REQUIRED

HORIZONTAL REBAR SPACING

#4 BARS @ 24" O.C.

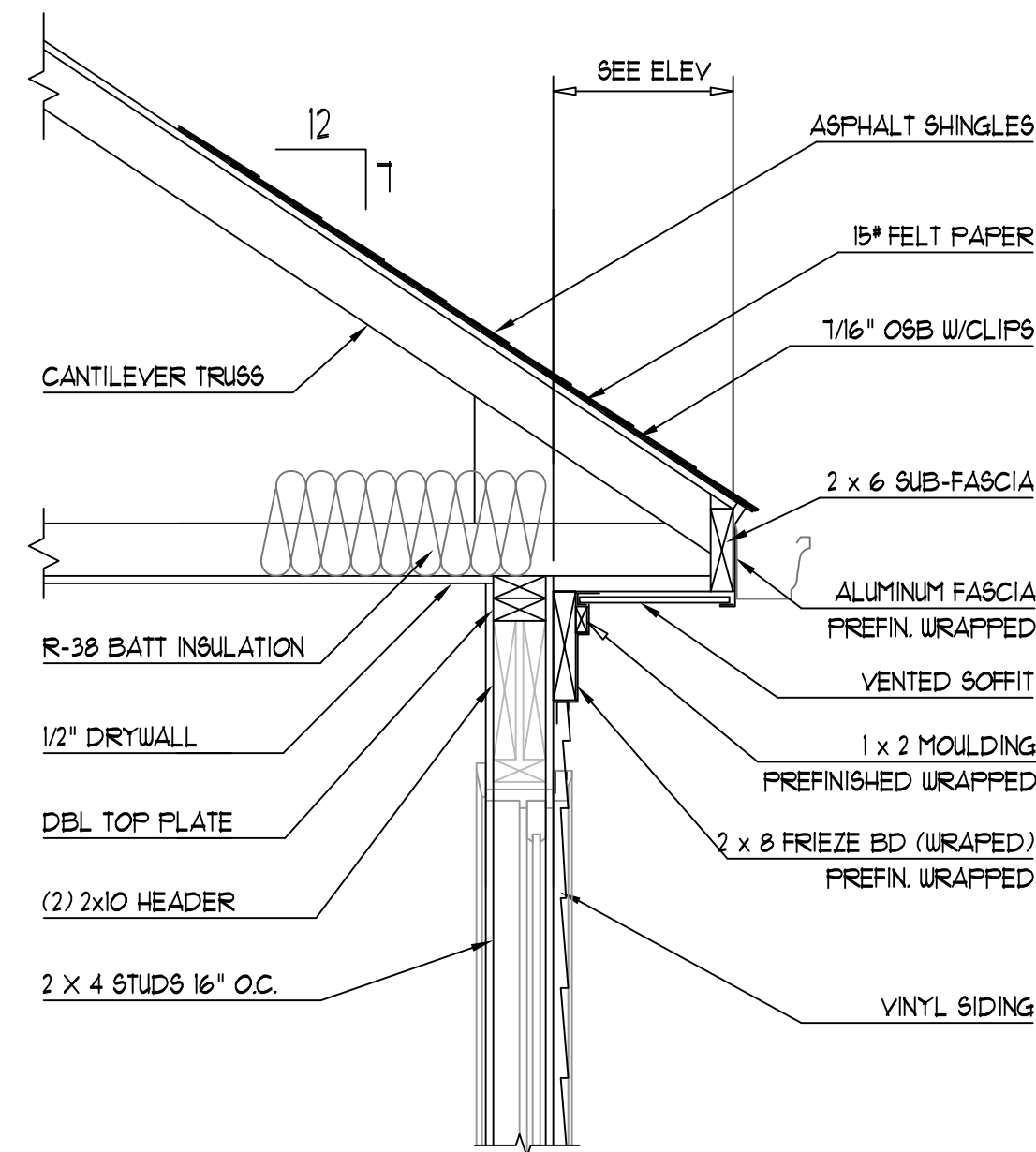

CANTILEVERED TRUSS OVERHANG

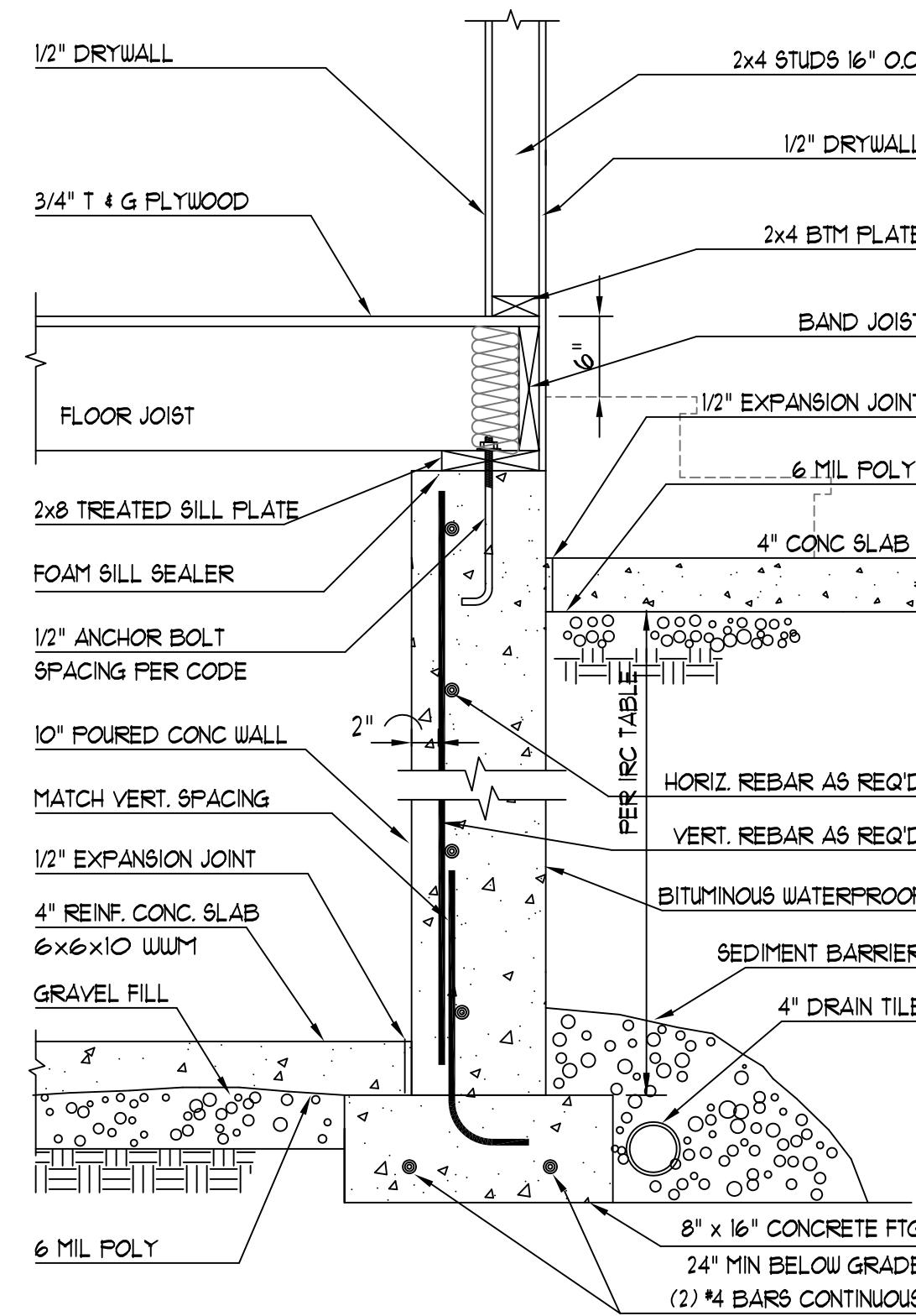

COMMON GARAGE WALL

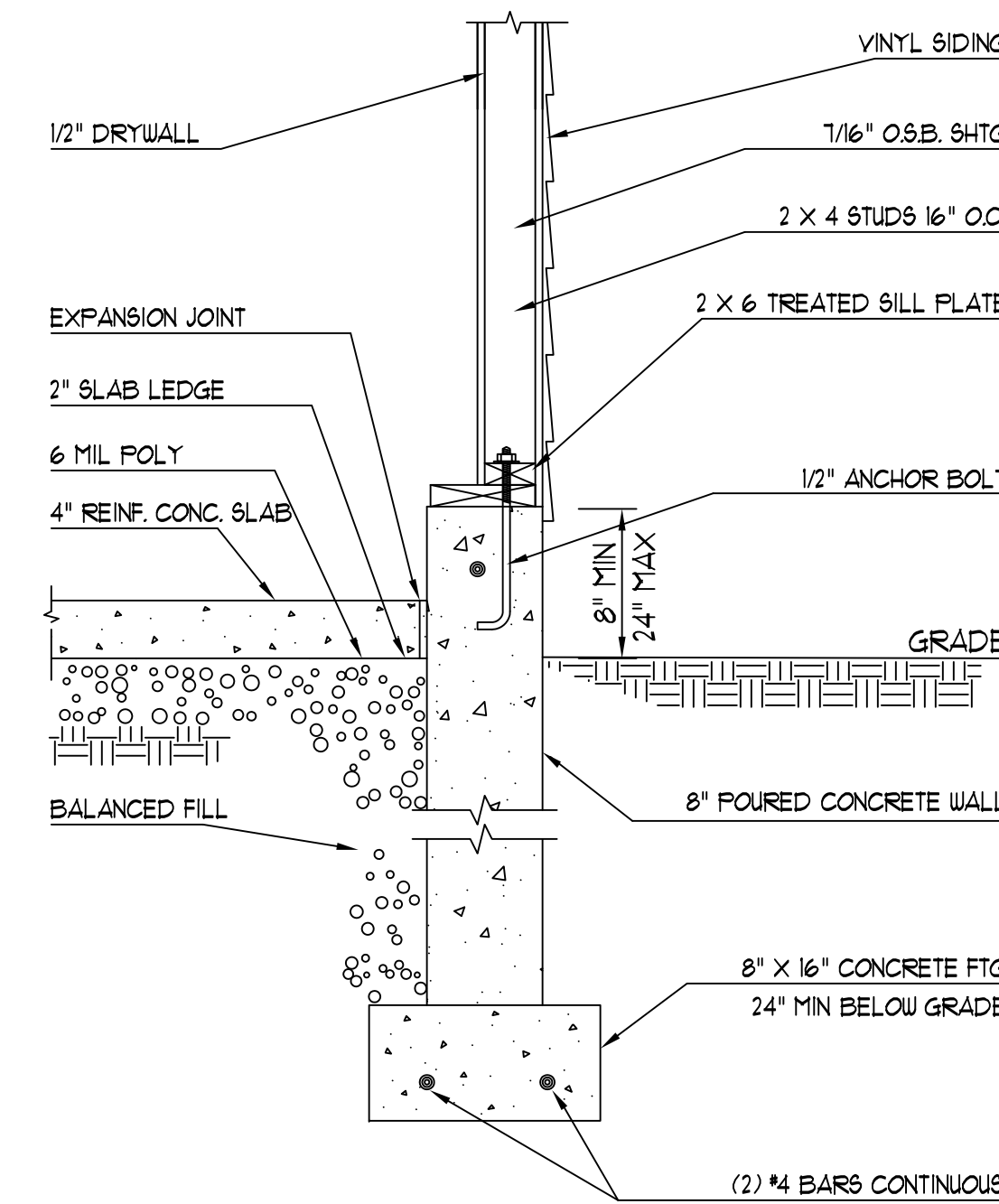

TYPICAL GARAGE WALL

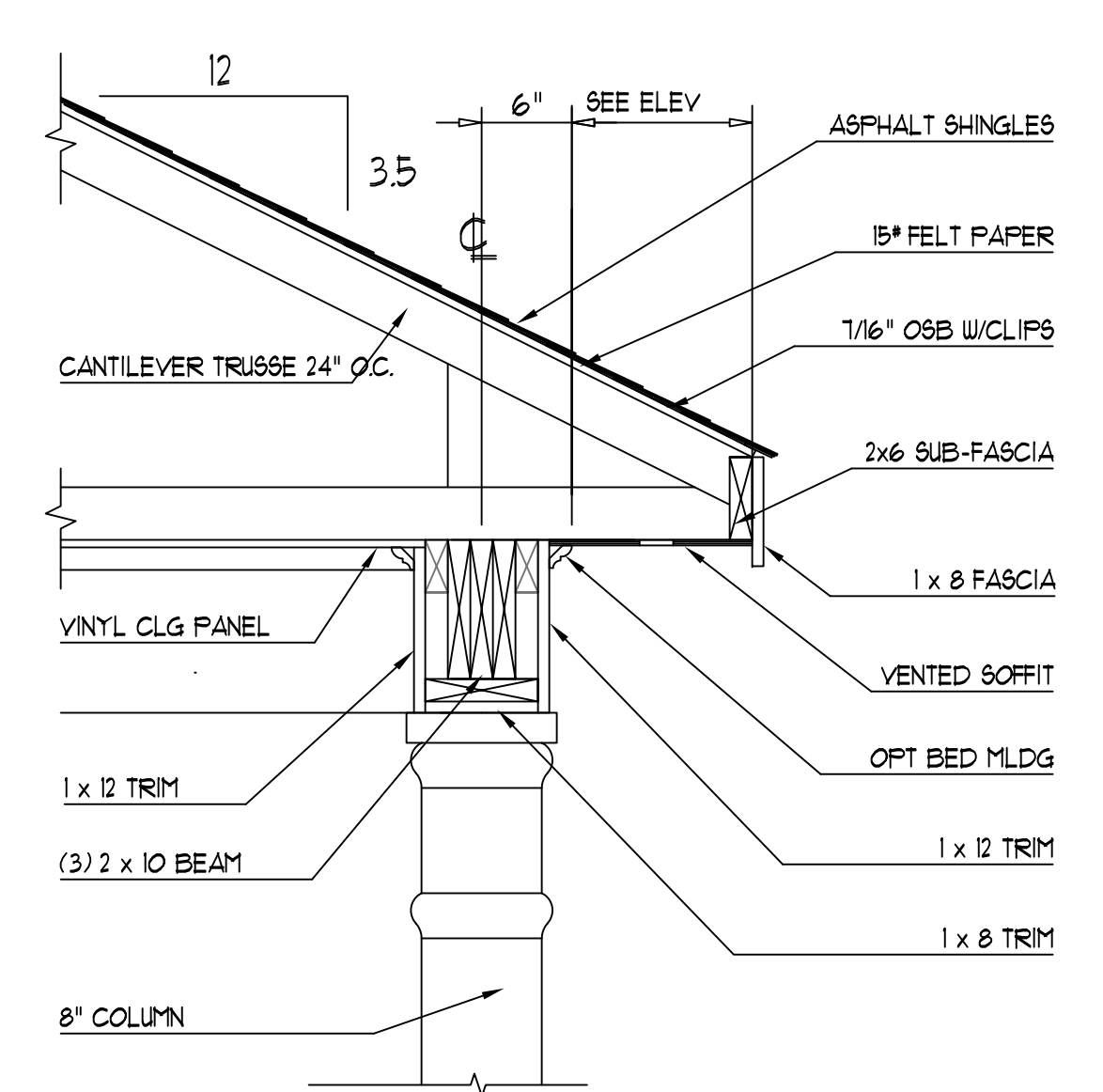

PORCH BEAM SECTION

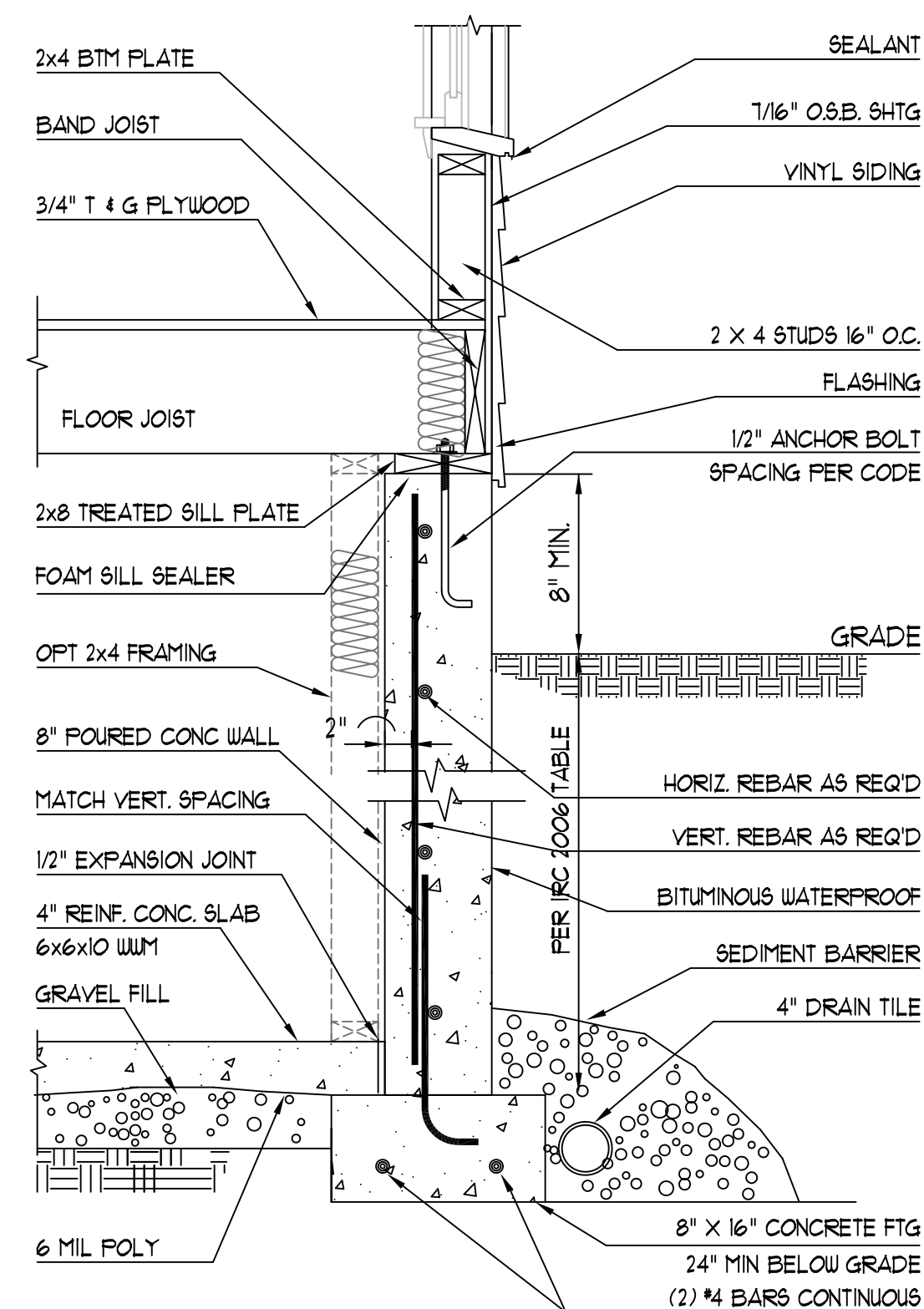

TYPICAL BASEMENT WALL SECTION

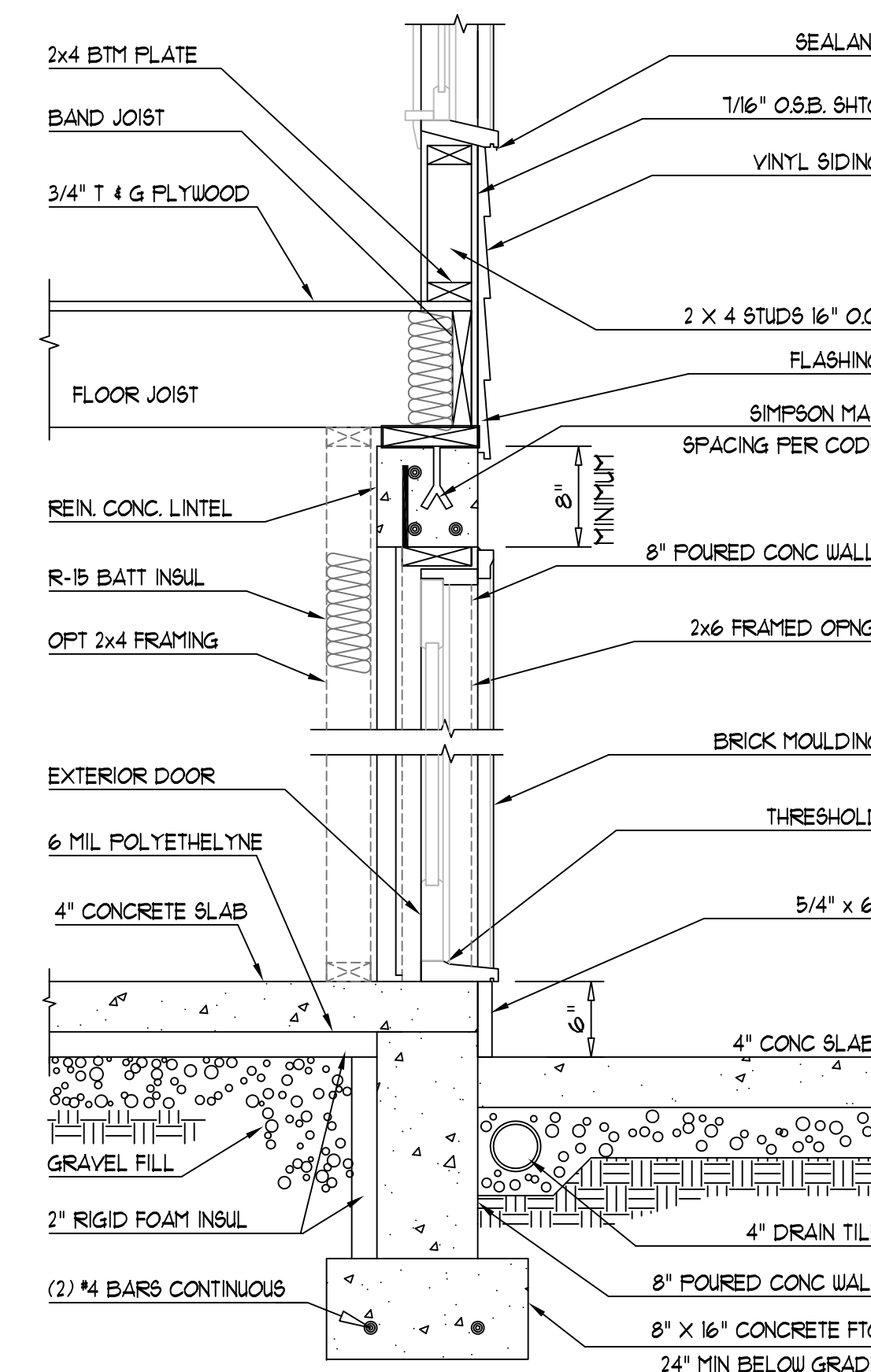

BASEMENT WALK-OUT CONDITION

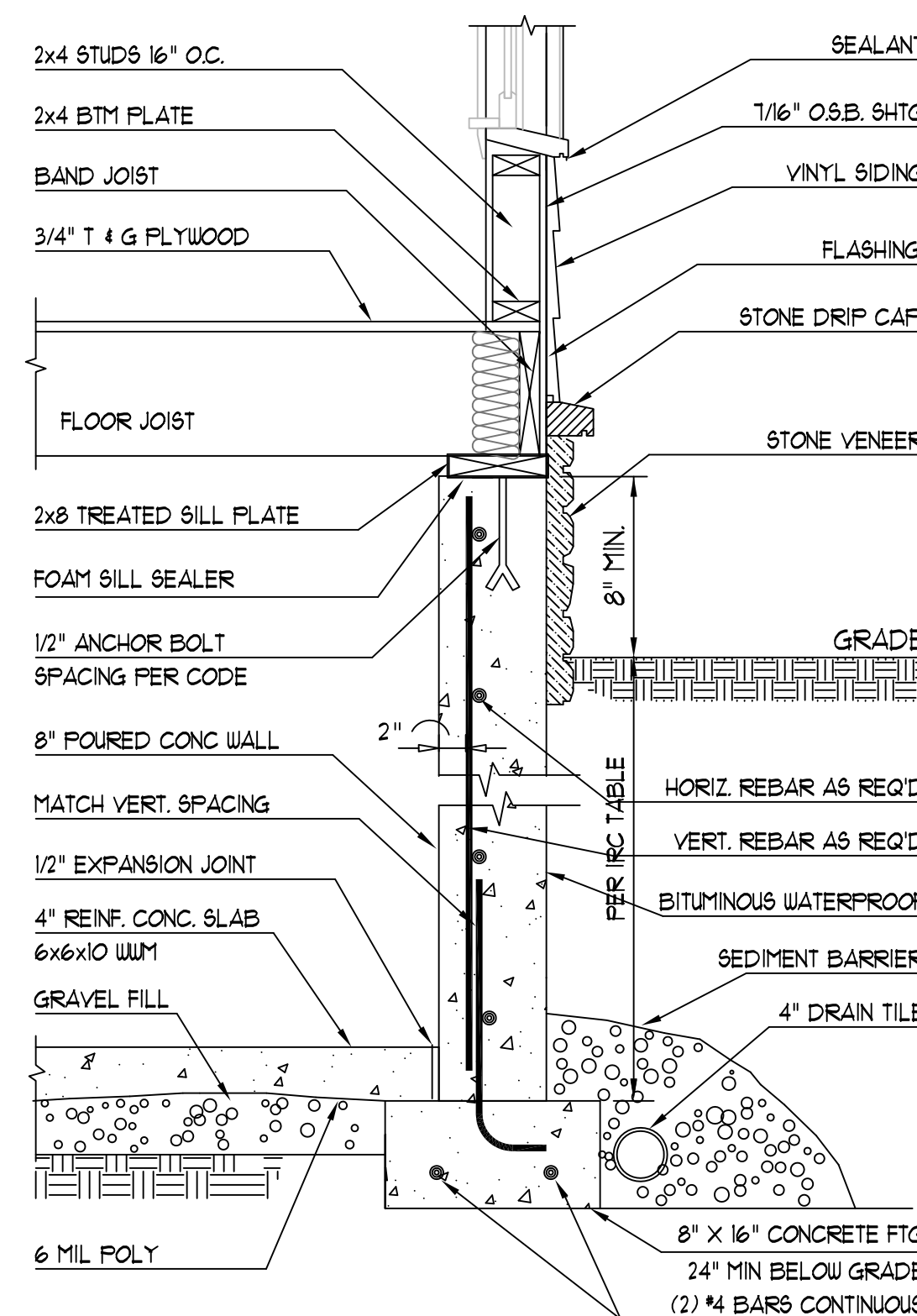

BASEMENT WALL WITH STONE FOUNDATION

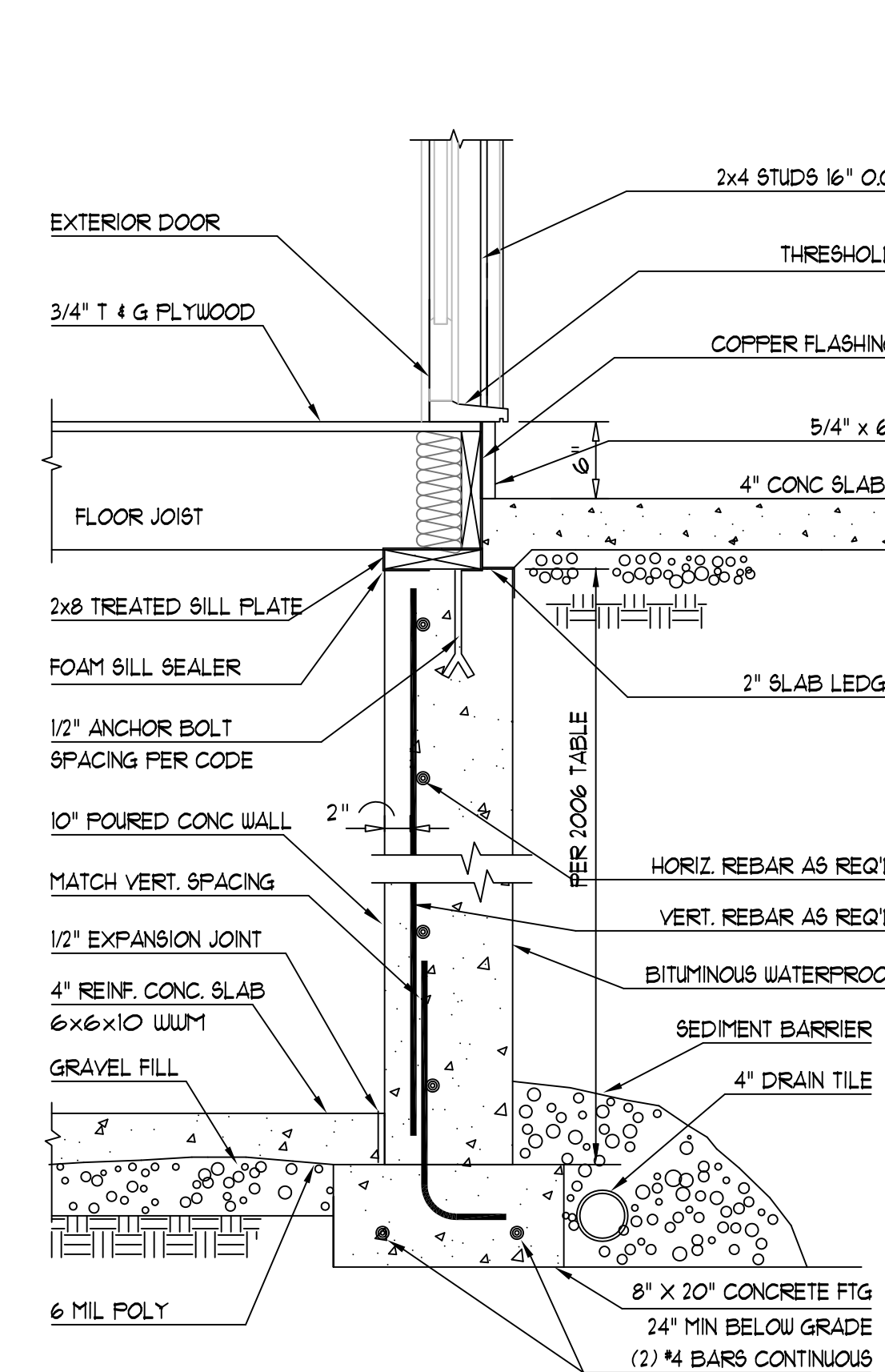

CONCRETE PORCH FLOOR WITH BASEMENT

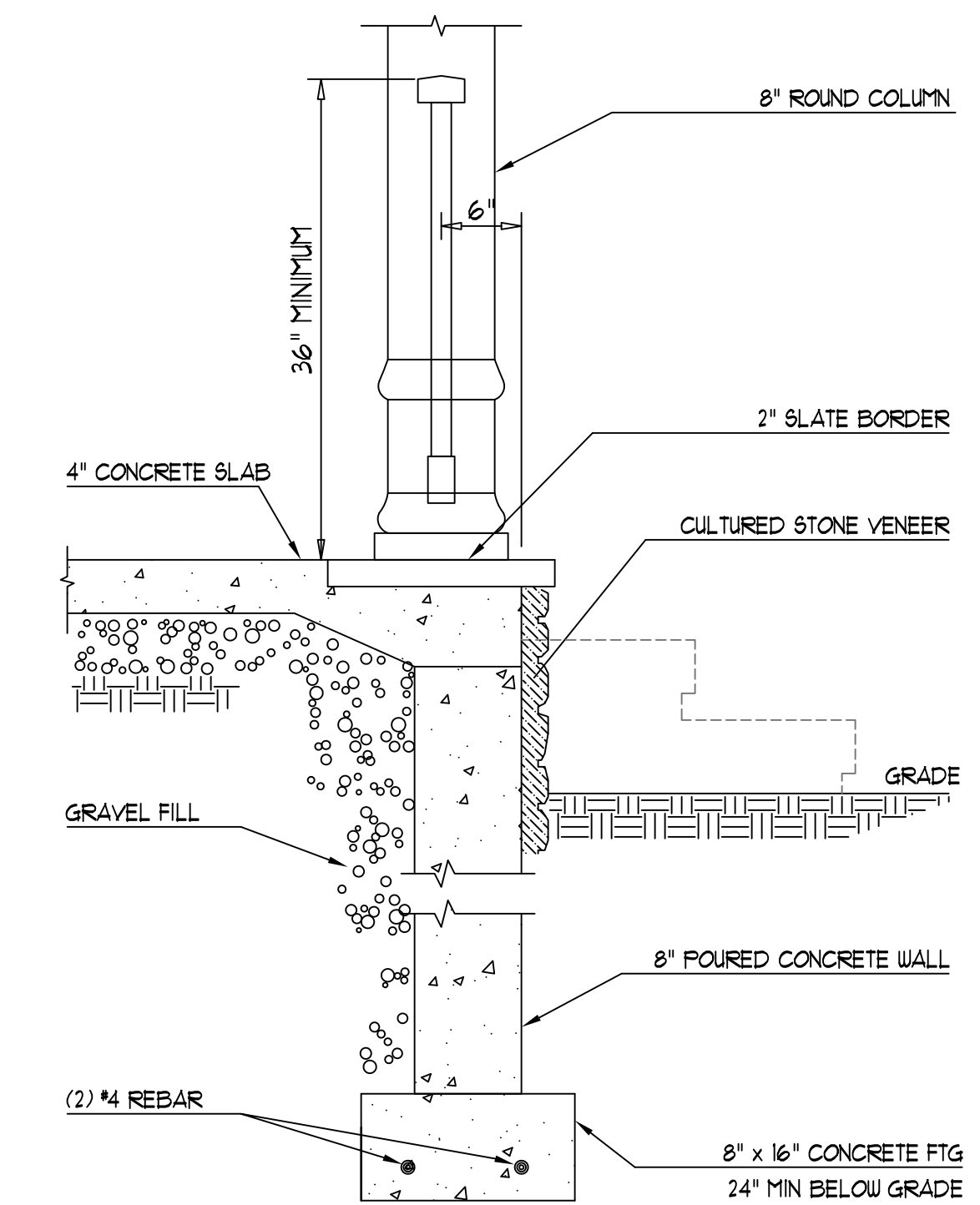

PORCH FLOOR WITH STONE VENEER

MISCELLANEOUS NOTES

GENERAL:

- All construction shall be in compliance with the International Residential Code 2012 & County regulations & amendments.
- Under the International Residential Code 2012, this case is classified as Construction type : 5B Unprotected & R3 use group .All relevant codes apply respectively.
- Construction documents shall be drawn upon suitable material, to an appropriate scale & of sufficient clarity to indicate the location, nature & extent of the work proposed, IRC 2012, Section R106.
- No inspection shall be carried out on site without the presence of the original red stamped approved copy.
- No changes or modification shall be made to the approved set of construction documents without prior approval of the building plan review and permits division.
- Call MISS UTILITY at 1-800-257-7777 before breaking ground, two days notice is required.

STRUCTURAL:

- For problem soils, a report signed & sealed by a professional soils engineer licensed to practice in the state of Virginia, shall be submitted prior to permit issuance for review & approval.
- Soil bearing capacity shall be set for 2000 psf, in accordance with IRC 2012, Table R401.4.1, unless a satisfactory soils report, signed & sealed by a professional soils Engineer is presented supporting the soil bearing capacity to be of different value.
- Minimum design live load values shall conform to IRC 2012, Table R 301.5.

Some of which are follows:

Attic w/ stair	Attic w/o stair	Bedrooms	Decks
20 psf	10 psf	30 psf	40 psf

balconies	handrails	other rooms	stairs
60 psf	200*	40 psf	40 psf

* Handrails should be designed to withstand any lateral force of 200 psf at any point.

Ground/Snow Load	Roof/Snow Load	Wind	Seismic Design	Frost Line Depth
35 psf	30 psf	90 mph	B	30 inches

- The residential construction design parameters are shown on the following table as amended from table R301.2(1) Subject to damage from

Weathering	Termite	Decay	Winter Design Temp.	Flood Hazard
Severe	Slight/Mid	Slight/Mid	By WSSC	Flood Map

5-Concrete in use shall comply with IRC 2012, Section 402.2.

6-All footings shall comply with IRC 2012, Section 403.3.

7- Sill plate at the top of foundation walls shall be secured with min, 1/2" anchor bolts set at 4' o.c. maximum & with 12" from ends of each plate section. The bolts shall extend min 7" into concrete or masonry. Approved foundation anchor straps that provide equivalent anchorage to 1/2" anchor bolts are acceptable, IRC 2012, Section 403.1.6.

8-Concrete & masonry foundation walls shall comply with IRC 2012, Section 404 thru R 406 as amended by the county.

9-Foundation drainage and water proofing shall comply with IRC 2012, Section 405 & section R 406 as amended by Subtitle 4, Section 4-196.

10-Stud spacing and sizes shall comply with IRC 2012, Section 602.3 & tables 602.3(5) and 603.3.1.

11-Exterior & interior wall bracing shall comply with IRC 2012, Section 602.10 & table R602.10.1.

12-For steel columns, AISC standard pipe shall be used, Schedule 40 pipes subtitle 4, section 4-197 when adjustable steel columns are proposed, load & moment calculations shall be assigned to designated columns, & an evaluation report for the column shall be attached for review.

13-For Manufactured wood joists & laminate beams, the layout, size, series number & manufacturer, must be clearly noted on the structural framing plans. In general glued laminated timber has to be manufactured and identified as required under AITC A 190.1 and ASTM D373, IRC 2012, Section R502.1

14-Cantilever spans for floor joists supporting light frame exterior bearing wall and roof only shall comply with IRC 2012, Section 502.3 and Table R502.3.3(1)

15-Wood roof truss drawings and calculations, must be present on the job at time of inspection

ARCHITECTURAL:

- Install interconnected smoke detectors in each sleeping room, outside of each sleeping area in the immediate vicinity of the bedrooms, and on each additional story of the dwelling, IRC 2012, Section R313.1
- Masonry veneer shall comply with IRC 2012, Section R703.7 and Table R 703.7.3
- Basement with habitable spaces and every sleeping room shall have at least one egress emergency escape & rescue opening. The minimum required openable area of the window is 5.7 sq.ft, minimum net height is 24", and/or 22" in case of a fully sprinklered dwelling as per IRC 2012, Section R310.2 as amended by subtitle 4, Section 4-243, the minimum net width is 20" and bottom sill height would be placed not higher than 44" above the finished floor, IRC2012, Section R310.1. Ceiling height shall be minimum 7'-0" measured from top of slab to finishing ceiling, and 6'-8" below beams, ducts, spaced not less than 4'-0" o.c.

4-Except in basements with total floor area not exceeding 400sq.ft. and/or fully sprinklered homes that comply with NEPA 13D: one exit from basement is required, one of which would be an exit door that leads directly to the outside grade or approved bedroom window egress. IRC2012, Section R311.4.5: Subtitle 4, Section 4-244(a).

5-Window wells shall comply with IRC2012, Section R310.2, and shall drain directly to the sump pump.*

6-Under floor spaces, commonly called crawl spaces have to comply with IRC2012, Section R408.

7- Glazing in locations subject to human impact or hazardous locations would comply with IRC 2012, Section R308.

8-Stairs & stairwells in dwellings shall comply with IRC 2012, Section 311.7. Treads minimum width shall be 9" and risers maximum height shall not exceed 8 1/2".

9-Garages beneath habitable areas shall be separated from those areas by not less than 5/8" type X gypsum board or equivalent IRC 2012, Section R309.2. Side hinged access doors to garages should carry a 20 minute fire rating label & should be equipped with self closing device.

10-As per IECC/IRC 2012, Table N1101.1 and N1102.1.1, the minimum required thermal performance values would state as follows:

Ceilings	Walls	Floors	Slab perimeter R value, depth
R-38	R-15	R-30	R-10, 2 ft

Crawl space walls	Basement walls	CLIMATE ZONE
R-15/19	R-15/19	4A

SQUARE FOOTAGE CALCULATIONS:

Square footage calculations are based on ANSI Z765 2009 standard. Calculations are taken from the exterior side of the sheathing. Stairs are counted as you descend (both first floor & second floor stairs are included). Floors open to below are not included. Bonus Rooms require a min. 50% of the floor space to have a ceiling height of 7' or greater to be included. No space with less than 5' knee walls is included.

General Notes

General notes are acknowledged and shall be adhered to during the construction

Misc. Notes:

- all work including all structural, HVAC, electrical & other shall be performed in accordance with all applicable national, state & local codes regulations.
- contractor to verify & coordinate all the conditions & dimensions at the site before beginning of construction. Any discrepancies shall be reported to Applied Civil Engineering immediately.
- all dimensions should be read or calculated & never scaled. 4- all pre-fab, materials, equipment, fixtures, & etc. shall be installed per manufacturer's instructions & requirements.
- pre-fab floor & trusses shall be designed for the loads indicated by professional engineer licensed to practice in the state of Virginia. Shop drawings shall be submitted to Applied Civil Engineering & the building inspector prior to fabrication.
- this set of drawings is intended to satisfy the record jurisdiction permit submission requirements only & does not accurately represent all documentation required to complete construction. Owner shall assume responsibility for any conflicts arising out of use of these drawings for constructions

Project Data

1- INTERNATIONAL BUILDING CODE (IBC) 2012 EDITION CONSTRUCTION CLASSIFICATION TYPE: 5B (unprotected), USE GROUP: R3,

2- INTERNATIONAL RESIDENTIAL CODE (IRC), 2012 EDITION

Construction:

First Floor	Wood
Second Floor	Wood
Roof	Wood
Walls	Wood

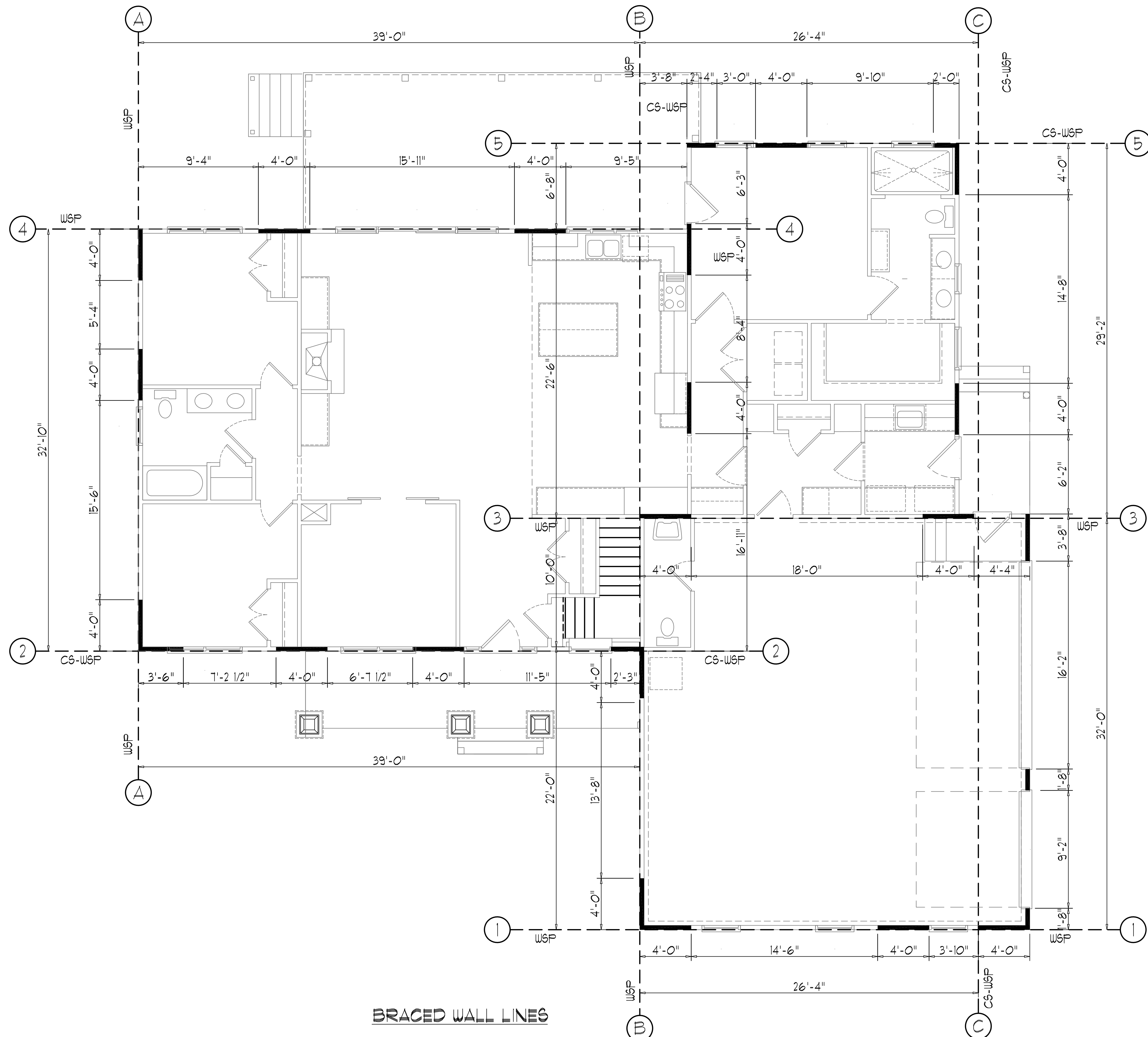

BRACED WALL LINES

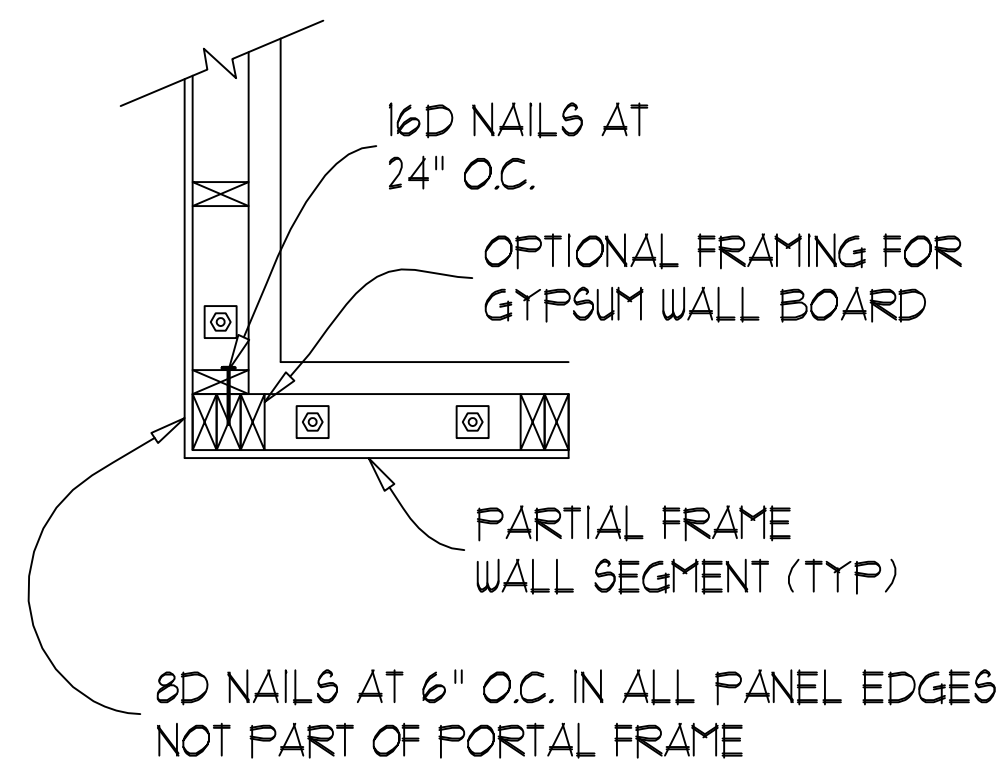

CORNER FRAMING DETAIL

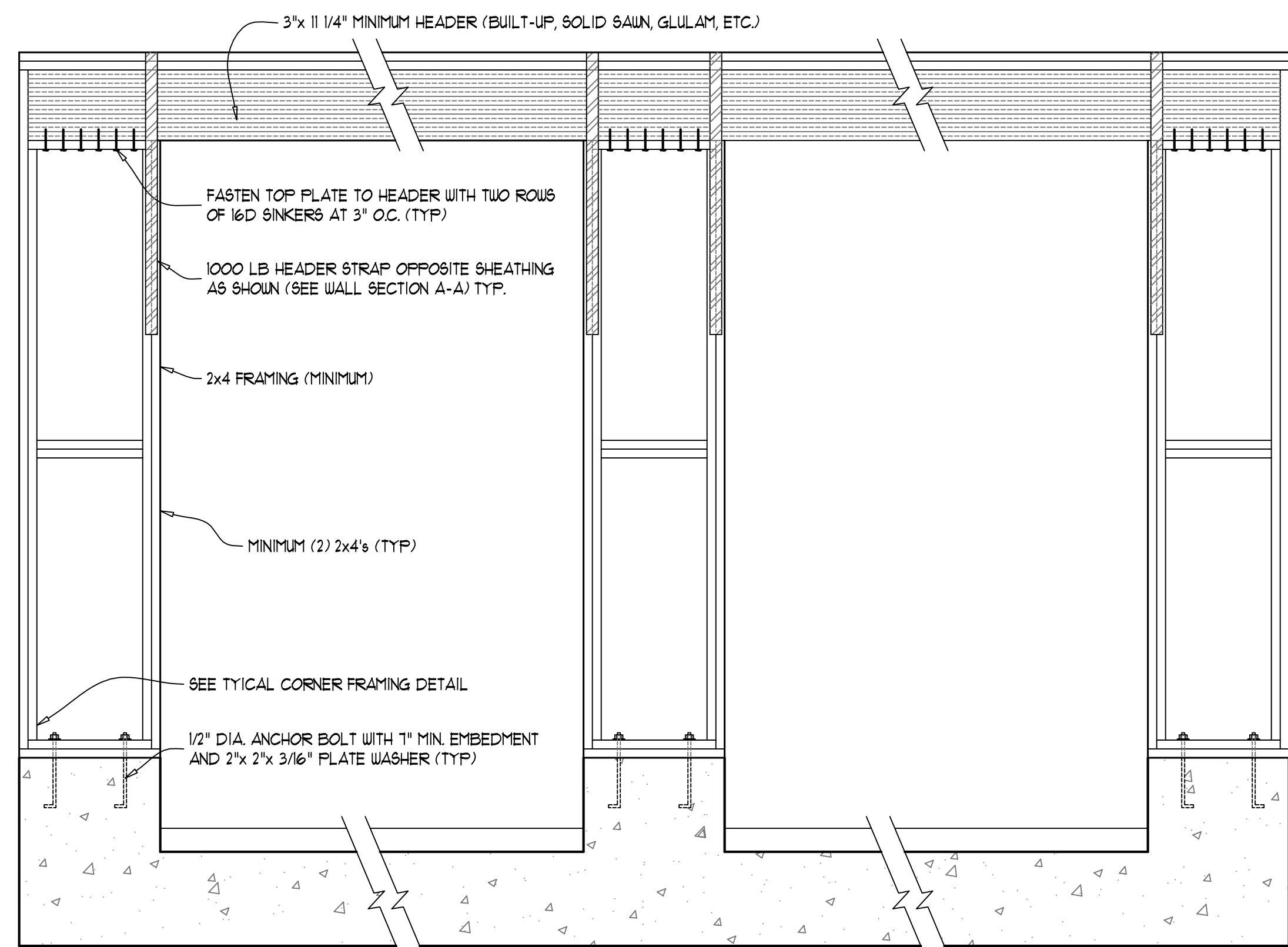

INSIDE ELEVATION

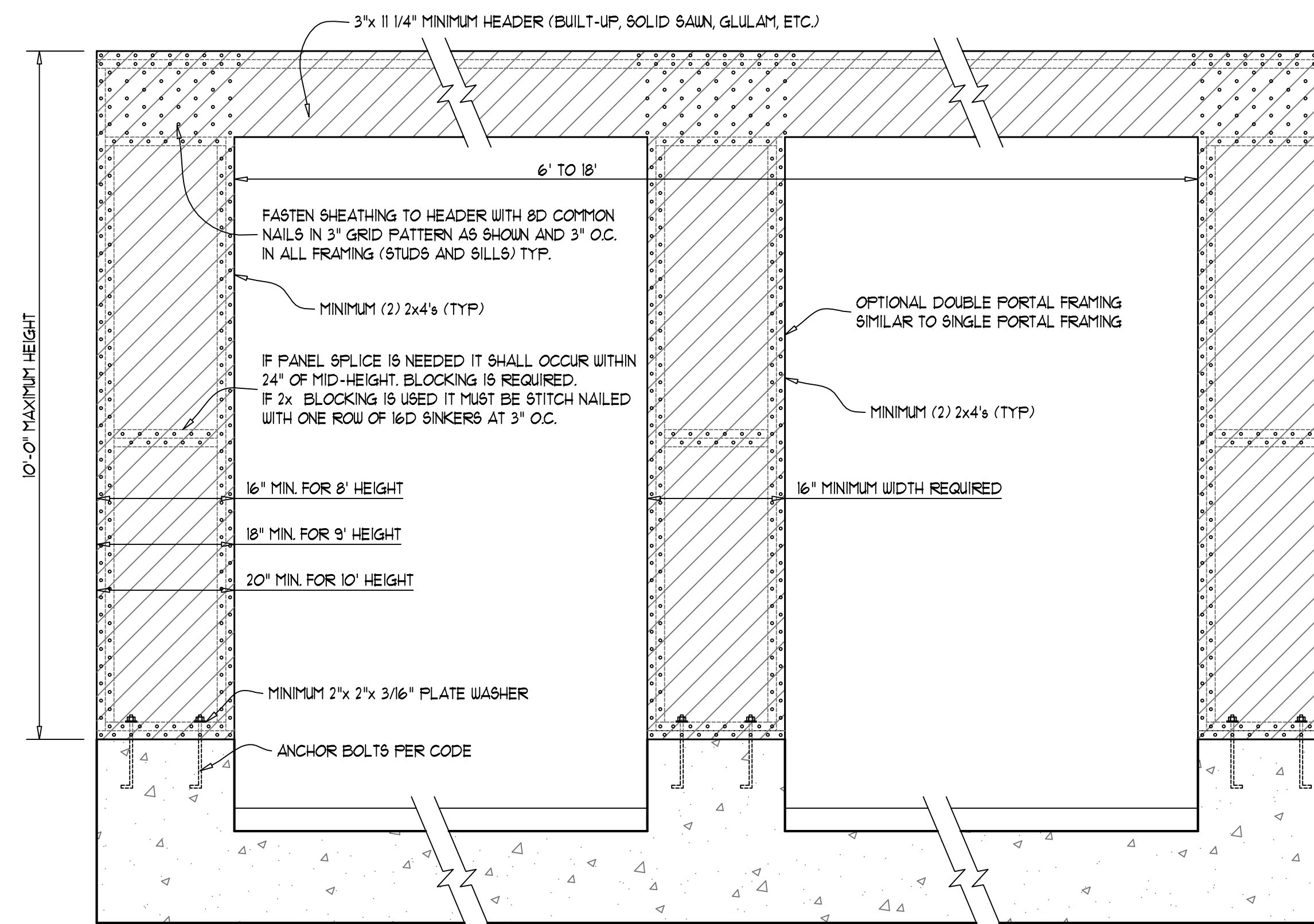

OUTSIDE ELEVATION

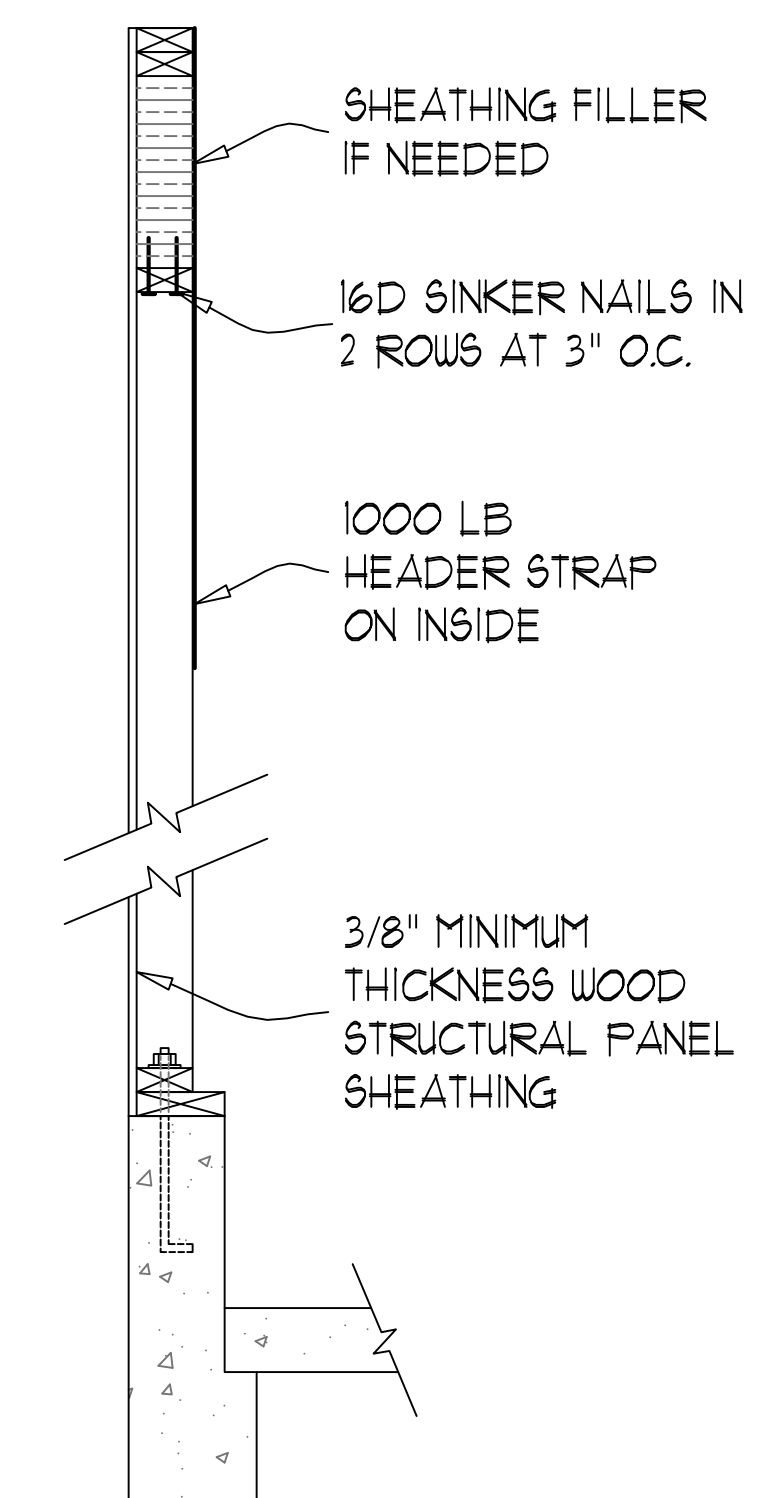

WALL SECTION A-A

GARAGE PORTAL FRAMING WITHOUT HOLD-DOWNS

IRC CODE SECTION R602

